

Aggregate Laboratory Workbook

Certified Inspector
Training Program

Aggregate Laboratory Tester Certification Workbook

Table of Contents

Click on the section name below to be taken to the correct page.

1. [KT-6 Specific Gravity and Absorption of Aggregates](#)
2. [KT -31 Percentage of Crushed Particles in Crushed Gravel](#)
3. [KT -55 Plastic Fines in Combined Aggregates \(Sand Equivalent Test\)](#)
4. [KT 59 Flat and Elongated Particles in Coarse Material](#)
5. [5.9 Sampling & Test Method Forward KT-15 and KT-20](#)
6. [Special Provisions](#)
7. [Performance Checklists](#)

AGGREGATE LABORATORY TESTER CIT PROGRAM

Written Test: Open book – 50 multiple choice questions

Grading: Must score at least 60% on each section of the written exam with an overall score of 70% or better to pass. Failure on any part of the written exam requires retaking the entire exam.

Must pass all performance exam sections. Failure of three or less performance subtest requires retest on only the subtest(s) failed. Failure of four or more subtests of the performance exam requires retest on the entire performance exam.

Exam Results: Exams will be graded in two to three weeks. Exam results are emailed to the student. Exam results are not given over the phone.

Exam Re-takes: Students who need to re-take either the written and/or performance exam need to register to do so. The re-take registration form can be found on the CIT website at www.citksu.com.

To be Certified: Students must successfully pass the written exam and the performance exam. The student will be mailed a certification card and letter.

Reasons for Certified Inspector Training (CIT) Training Program

Overview

The Kansas Department of Transportation (KDOT) has established this training program to educate, test and certify those individuals responsible for performing inspection and testing functions on KDOT construction projects. KDOT's Bureau of Construction and Materials has responsibility for the establishment and administration of the materials portion of the KDOT's Quality Control/Quality Assurance (QC/QA) Program. The Bureau develops standards and specifications for materials, establishes sampling procedures and frequencies, and test procedures used in the laboratory and the field in order to assure compliance with specifications. It performs materials testing to assist each of the six KDOT districts in administering quality assurance functions of the QC/QA Program. Such testing includes tests on materials purchased by contractors or the State for use in maintenance or construction activities. The Bureau also conducts tests on soils, concrete, bituminous mixtures and numerous other specialized materials, the results of which are used by others for a variety of reasons.

Quality control and quality assurance activities involve the routine sampling, testing and analysis of various materials to determine the quality of a given product and to attain a quality product. The goal of the Certified Inspection and Testing Training Program (CIT²) is to provide persons engaged in the inspection and/or testing of KDOT construction projects specific training in, but not limited to, soils, aggregates, and concrete and/or asphalt disciplines.

Each student is required to demonstrate specific abilities as defined by the training modules described in the CIT² manual. The manual can be found online at: <http://www.ksdot.org/descons.asp#CIT>.

Federal Funding

On projects involving federal funds, KDOT must certify to the Federal Highway Administration as to the quality of each type of material used on each project before the State is completely reimbursed by the federal government.

The certification and training requirements contained in this manual are intended to comply with the requirements of 23 CFR Part 637 which states, "After June 29, 2000, all sampling and testing data to be used in the acceptance decision or the IA (Independent Assurance) program shall be executed by qualified sampling and testing personnel."

Reasons for Quality Control/Quality Assurance

Inspectors fulfill a very important job on any project—they safeguard the public interest in a number of ways.

The primary reason for materials inspection, sampling and testing requirements is to verify that all materials incorporated into the work will meet the requirements of the contract documents, including the plans, specifications, and special provisions.

Plans and specifications are prepared to require the use of certain specific materials known or expected to perform satisfactorily with minimum maintenance throughout the life of the facility or infrastructure project. Any material that deviates appreciably from the specifications requirements will not perform as expected and, in all probability, will shorten the useful life of the facility or add unexpected costs in maintenance. Because there are limited dollars available for transportation infrastructure, the useful life and long-term maintenance costs of every project are critical considerations.

Secondly, all contractors bidding or furnishing materials to a project should be treated equally. That is, the contract documents provide a fair and uniform basis for bidding because they define the requirements to be met—ideally with the least possible difference of interpretation. The contractor commits to furnish materials and complete work that will equal or exceed such requirements. For this reason it is essential that quality assurance be correctly understood and applied uniformly by engineers and inspectors from project-to-project so that all contractors and suppliers are treated alike.

Thirdly, the expenditure of public funds must be documented to substantiate whether taxpayers actually received the quantity and quality of materials specified in exchange for tax dollars spent. Whether or not to pay the costs invoiced by contractors is a decision which relies heavily upon inspection reports and test results. In a fundamental way, inspectors play a key role in serving the public—to justify the expenditure of public monies and the acceptance of any contractor's work. Through the work of knowledgeable, competent and skilled inspectors, KDOT can verify and confirm whether or not the contractor has fulfilled its obligations to build the project as intended.

Finally, the specification requirements for materials are constantly evolving, based on new developments, past performance of material in the field, research and technological innovations. Accurate recordkeeping of materials and test results using consistent inspection practices provides a basis to compare results over time—an indispensable advantage for meaningful research. Data properly collected and recorded by inspectors can confirm whether or not changes in material specifications and testing requirements have, in fact, resulted in a better product, state-wide or in a particular location or application.

All inspectors should review the applicable clauses of the Standard Specifications at regular intervals to refresh their understanding of material and testing requirements.

Course Overview

Lecture and Demonstrations Videos

- Homework and Lab worksheets

Performance Exam

- Converted to written exam covering methods:
 - KT-6 [Procedure 1]
 - KT-6 [Procedure 2]
 - KT-31
 - KT-55
 - KT-59

Written Final Exam with 50 questions

- 10 questions from KT-6 [Procedure 1]
- 10 questions from KT-6 [Procedure 2]
- 10 questions from KT-31
- 10 questions from KT-55
- 10 questions from KT-59



1

KT-6

PROCEDURE 1: COARSE AGGREGATE

SPECIFIC GRAVITY AND ABSORPTION OF AGGREGATES

2

KT-6 Specific Gravity and Absorption of Aggregates

Scope

- Determining the specific gravity and absorption of aggregates.
- Coarse aggregate or aggregate retained on the No. 4 sieve will be discussed in procedure I
- Fine aggregate or all aggregate passing the No. 4 sieve and retained on the No. 100 will be discussed in procedure II

3

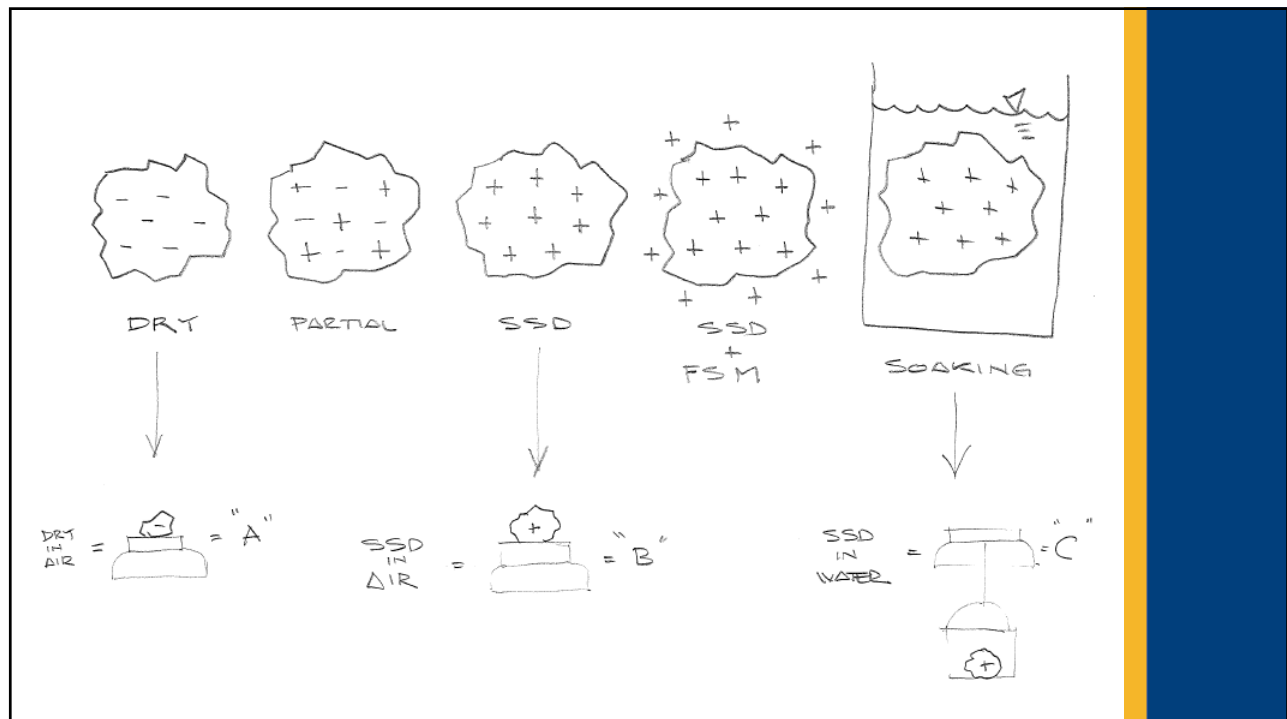

4

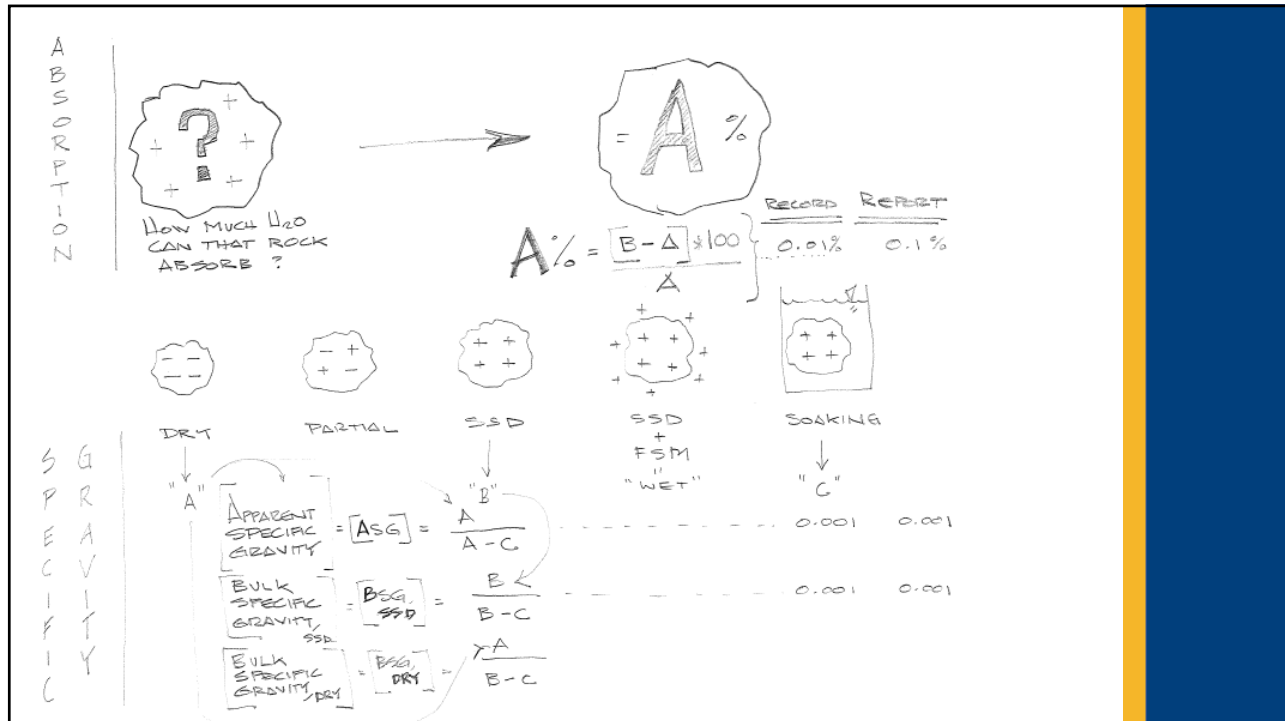

5

KT-6 Specific Gravity and Absorption of Aggregates

Referenced Documents and Methods

- Construction Manual Part V, 5.9; Sampling and Testing Foreword
- KT-1; Sampling and Splitting of Aggregates
- KT-11; Moisture Tests
- KT-24; Determination of Free Moisture or Absorption of Aggregate for Use in Concrete
- AASHTO M 92; Wire-Cloth Sieves for Testing Purposes
- **AASHTO T 84; Specific Gravity and Absorption of Fine Aggregates**
- **AASHTO T 85; Specific Gravity and Absorption of Coarse Aggregates**
- ASTM C 128; Method for Density, Relative Density (Specific Gravity), and Absorption of Fine Aggregate
- ASTM C 670; Practice for Preparing Precision and Bias Statements for Test Methods for Construction Materials

6

KT-6 Specific Gravity and Absorption of Aggregates Procedure I

Apparatus

- A balance, Class G5 according to Sampling and Test Methods Foreword
- Container with overflow for immersing the bucket in water maintained at $77 \pm 2^{\circ}\text{F}$
- Bucket approximately 8" in diameter and 8" in height
- Drying oven capable of maintaining a uniform temperature of $230 \pm 9^{\circ}\text{F}$ ($110 \pm 5^{\circ}\text{C}$)
- Drying Pans
- Absorbent Cloth
- Standard No. 4 sieve meeting requirements of AASHTO M 92

7

KT-6 Specific Gravity and Absorption of Aggregates Procedure I

Sample Preparation

- The samples are normally comprised of an aggregate that passes the 2" sieve and is retained on the No 4 sieve. Use of larger aggregate should be noted in the report
- Split and quarter a portion of the aggregate as specified in KT-1
- Sieve the material through the 2" to the No 4 sieve
- Use Table 1 to determine minimum sample size

8

KT-6 Specific Gravity and Absorption of Aggregates Procedure I

Sample Preparation

- Wash sample over the No. 4 to remove the dust (check water clarity)
- After washing, dry the sample to constant mass which usually takes 15 to 16 hours (**constant mass is defined as the mass changing by no more than 0.1% after 1 hour in an oven at $230 \pm 9^{\circ}\text{F}$**)
- See note pertaining to concrete mix designs

9

KT-6 Specific Gravity and Absorption of Aggregates Procedure I

Test Procedure

- Immerse sample in water and stir, allow to soak for **24 ± 4 hours**
- After immersion period, remove sample and reach a saturated surface dry (SSD) condition by rolling the sample in a damp, absorbent cloth
- Weigh the sample immediately after achieving SSD conditions determined to **nearest 1 g or 0.1% of sample mass**, whichever is greater (record this value as "B")

10

KT-6 Specific Gravity and Absorption of Aggregates Procedure I

Test Procedure

- After recording the SSD weight, immerse the sample in water at _____ and stir to remove entrapped air (record this weight as "C")
- Dry the sample to constant mass (what is considered constant mass?) at _____
- Cool the sample at room temperature until the sample is able to be handled and determine the mass (record this weight as "A")

11

KT-6 Specific Gravity and Absorption of Aggregates Procedure I

Calculations

Nomenclature

- A = Mass of oven-dry sample in air, g
- B = Mass of surface-dry sample in air, g
- C = Mass of saturated sample in water, g

12

KT-6 Specific Gravity and Absorption of Aggregates Procedure I

Calculations

- Bulk Specific Gravity
 - $\frac{A}{B-C}$
- Bulk Specific Gravity SSD Basis
 - $\frac{B}{B-C}$
- Apparent Specific Gravity
 - $\frac{A}{A-C}$
- % Absorption
 - $100\% * \frac{B-A}{A}$

13

KT-6 Specific Gravity and Absorption of Aggregates Procedure I

Reporting

- Record specific gravities to the nearest 0.001
- Record the absorption to the nearest 0.01%
- Report all specific gravities to the nearest 0.001 and indicate type
- Report the absorption to the nearest 0.1%

14

KT-6 Specific Gravity and Absorption of Aggregates Procedure I

Example

- A coarse aggregate sample had the following masses associated with it after conducting a KT-6 Procedure I
- Saturated Surface Dry in Air (B): 2817.4 g
- Saturated Surface Dry in Water (C): 1714.3 g
- Oven Dry in Air (A): 2733.6 g

15

KT-6 Specific Gravity and Absorption of Aggregates Procedure I

What is the Recorded and Reported Bulk Specific Gravity for the coarse aggregate sample?

$$\frac{A}{B - C}$$

$$\frac{2733.6}{(2817.4 - 1714.3)} = 2.478$$

16

KT-6 Specific Gravity and Absorption of Aggregates Procedure I

What is the Recorded and Reported Bulk Specific Gravity (saturated surface dry) for the aggregate sample?

$$\frac{B}{B - C}$$

$$\frac{2817.4}{2817.4 - 1714.3} = 2.554$$

17

KT-6 Specific Gravity and Absorption of Aggregates Procedure I

What is the Recorded and Reported Apparent Specific Gravity for the aggregate sample?

$$\frac{A}{A - C}$$

$$\frac{2733.6}{2733.6 - 1714.3} = 2.682$$

18

KT-6 Specific Gravity and Absorption of Aggregates Procedure I

What is the Recorded and Reported absorption % for the aggregate sample?

$$\frac{100 \times (B - A)}{A}$$

$$\frac{100 \times (2817.4 - 2733.6)}{2733.6} = \begin{matrix} 3.07\% \text{ (Recorded)} \\ 3.1\% \text{ (Reported)} \end{matrix}$$



1

KT-6 Specific Gravity and Absorption of Aggregates: Procedure 2

Apparatus

- A balance, class G2, reads to 0.1 g and accurate to 0.2 g or 0.1%
- Volumetric flask of known mass with a minimum capacity of 500 mL
- Calibrated by the manufacturer to within:
 - 0.20 mL at 68°F (20°C) for a 500 mL flask
 - 0.30 mL at 68°F (20°C) for a 1000 mL flask
- At least 2 drying pans
- Drying oven capable of maintaining a temperature of $230 \pm 9^\circ\text{F}$
- Water bath with at least a 2-gallon capacity and maintained at $77 \pm 2^\circ\text{F}$ with a depth approximately equal to the height of the bowl of the flask
- No. 4 Sieve
- No. 100 Sieve

2

KT-6 Specific Gravity and Absorption of Aggregates: Procedure 2

Sample Preparation

- Sample consists of material passing the No. 4 and retained on the No. 100
- Split and quarter the sample as shown in KT-1
- The size of the sample should be at a minimum 1000 g
- Screen material over the No. 4, discarding any retained material
- Wash all the material passing the No. 4 over the No. 100 sieve
- Dry material passing the No. 4 and retained on the No. 100 to constant mass
- See note pertaining to concrete mix designs
- Screen material over the No. 4, discarding any retained material
- Wash all the material passing the No. 4 over the No. 100 sieve
- Dry material passing the No. 4 and retained on the No. 100 to constant mass
- See note pertaining to concrete mix designs

3

KT-6 Specific Gravity and Absorption of Aggregates: Procedure 2

Test Procedure

- Immerse the sample in water and stir, allow to soak for 24 ± 4 hours
- Remove sample from water and bring it to a SSD condition:
 - Place saturated sample in a drying pan and allow to dry in air for a short period while stirring regularly
 - Transfer sample to another drying pan
 - Stir sample while checking for the presence of free moisture, indicated by a change in color at the bottom of the pan
 - Stir and transfer the sample from pan to pan until no moisture is detected in the pan
 - Determine mass of empty flask and record as "F"
- Immediately after achieving the SSD condition, split and weigh out a sample of at least 500 g (record this value as "B") and place in the flask
- Fill the flask with water until the level is slightly below the calibrated mark (reading from the meniscus) with water at $77 \pm 2^\circ\text{F}$ ($25 \pm 1^\circ\text{C}$)

4

KT-6 Specific Gravity and Absorption of Aggregates: Procedure 2

Test Procedure Continued...

- Rotate the flask at a slightly inclined position to eliminate air bubbles (Do not shake!), allow flask to sit for several minutes and roll again until a time of 15 minutes is reached or there are no air bubbles
- Place flask in water bath until the temperature of the material inside the flask is the same as the bath
- Fill the flask the rest of the way to the calibrated mark with water and wipe away all surface moisture
- Weigh the flask and its contents to the nearest 0.1 g (record as "K")
- Remove the aggregate from the flask and dry to a constant mass in an oven at
- Let the sample cool to room temperature and weigh (record as "A")

5

KT-6 Specific Gravity and Absorption of Aggregates: Procedure 2

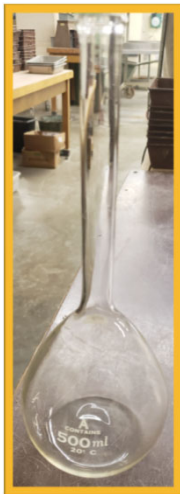

Verification of Calibration

- Determine the mass of the flask filled to the calibration mark with water at 77°F
- Subtract the mass of the empty flask and determine the mass of water the flask will hold (record value as "C")
- This final calibration step for determining "C" need only be performed once every 12 months

6

KT-6 Specific Gravity and Absorption of Aggregates: Procedure 2

Nomenclature for Calculations

- W = Mass of water added to the flask, g
- F = Mass of empty flask, g
- K = Mass of flask plus water and sample once filled to calibration mark, g
- A = Mass of oven dry sample in air, g
- B = Mass of saturated surface dry sample in air, g
- C = Mass of water the flask will hold filled to the calibration mark at 77°F, g

7

KT-6 Specific Gravity and Absorption of Aggregates: Procedure 2

Calculations



- **Weight of water added to the flask**
 - ❖ $W = K - (F + B)$
- **Bulk Specific Gravity**
 - ❖ $\frac{A}{C-W}$
- **Bulk Specific Gravity SSD Basis**
 - ❖ $\frac{B}{C-W}$
- **Apparent Specific Gravity**
 - ❖ $\frac{A}{(C-W)-(B-A)}$
- **% Absorption**
 - ❖ $100\% * \frac{B-A}{A}$

8

KT-6 Specific Gravity and Absorption of Aggregates: Procedure 2



Reporting

- Record specific gravities to the nearest **0.001**
- Record the absorption to the nearest **0.01%**
- Report all specific gravities to the nearest **0.001** and indicate type
- Report the absorption to the nearest **0.1%**

9

KT-6 Specific Gravity and Absorption of Aggregates: Procedure 2

Example

- ❖ A fine aggregate sample had the following masses associated with it following a *KT-6 Procedure II*
 - Mass of water the flask holds to the calibrated line at 77°F (C): **996.2 g**
 - Mass of saturated surface dry sample in air (B): **530.1 g**
 - Mass of empty flask (F): **315.8 g**
 - Mass of flask + sample + water to calibration mark (K): **1639.5 g**
 - Mass of water added to the flask (W): $K - (F + B) = 793.6 \text{ g}$
 - Mass of oven dry sample in air (A): **527.4 g**

10

KT-6 Specific Gravity and Absorption of Aggregates: Procedure 2

Bulk Specific Gravity

$$\frac{A}{[C - W]}$$
$$\frac{527.4}{996.2 - 793.6} = 2.603$$

11

KT-6 Specific Gravity and Absorption of Aggregates: Procedure 2

Bulk Specific Gravity [SSD]

$$\frac{B}{[C - W]}$$
$$\frac{530.1}{996.2 - 793.6} = 2.617$$

12

KT-6 Specific Gravity and Absorption of Aggregates: Procedure 2

Apparent Specific Gravity

$$\frac{A}{(C - W) - (B - A)}$$

$$\frac{527.4}{(996.2 - 793.6) - (530.1 - 527.4)} = 2.638$$

13

KT-6 Specific Gravity and Absorption of Aggregates: Procedure 2

What is the Recorded and Reported **Absorption** % for the fine aggregate sample?

$$\frac{100 \times (B - A)}{A}$$

$$\frac{100 \times (530.1 - 527.4)}{527.4} = 0.51\% \text{ (Recorded)}$$

$$0.5\% \text{ (Reported)}$$

14

KT-6 Specific Gravity and Absorption of Aggregates: Procedure 2

- Precision
 - The closeness of agreement among test results obtained under prescribed conditions
- Single Operator Precision
- Multi-laboratory Precision
- Standard Deviation
 - A measure of how spread out the numbers are
- See Table 2

5.9.06 SPECIFIC GRAVITY AND ABSORPTION OF AGGREGATES (Kansas Test Method KT-06)

1. SCOPE

This method of test covers the procedures for determining the specific gravity and absorption of aggregates. Coarse aggregate (Procedure I) represents aggregate retained on the No. 4 (4.75 mm) sieve. Fine aggregate (Procedure II) is all aggregate passing the No. 4 (4.75 mm) and retained on the No.100 (150 μ m) sieve. **KT-06** reflects testing procedures found in **AASHTO T 84** and **T 85**.

2. REFERENCED DOCUMENTS

2.1. Part V, 5.9; Sampling and Test Methods Foreword

2.2 KT-01; Sampling and Splitting of Aggregates

2.3. KT-11; Moisture Tests

2.4. KT-24; Determination of Free Moisture or Absorption of Aggregate for Use in Concrete

2.5. ASTM E11; Woven Wire Test Sieve Cloth and Test Sieves

2.6. AASHTO T 84; Specific Gravity and Absorption of Fine Aggregate

2.7. AASHTO T 85; Specific Gravity and Absorption of Coarse Aggregate

2.8. ASTM C128; Method for Density, Relative Density (Specific Gravity), and Absorption of Fine Aggregate

2.9. ASTM C670; Practice for Preparing Precision and Bias Statements for Test Methods for Construction Materials

3. PROCEDURE I: COARSE AGGREGATE

3.1. Apparatus

3.1.1. The balance shall conform to the requirements of **Part V, 5.9; Sampling and Test Methods Foreword**, Class G5. The balance shall be equipped with suitable apparatus for suspending the sample container in water from the center of weighing platform or pan of the balance.

3.1.2. Bucket approximately 8 in (200 mm) in diameter and 8 in (200 mm) in height.

3.1.3. Container with overflow for immersing the bucket in water.

3.1.4. Drying oven capable of maintaining a uniform temperature of $230 \pm 9^{\circ}\text{F}$ ($110 \pm 5^{\circ}\text{C}$).

3.1.5. Drying pans.

3.1.6. Absorbent cloth.

3.1.7. Standard No. 4 (4.75 mm) sieve meeting the requirements of **ASTM E11**.

3.2. Test Method

3.2.1. Sample Preparation: This test is normally conducted on the portion of the aggregate that passes the 2 in (50 mm) sieve and is retained on the No. 4 (4.75 mm) sieve. If the test is conducted on larger size particles, it shall be so noted on the test report.

3.2.1.1. Select a portion of the aggregate by splitting or quartering as specified in **KT-01, Section 4**. The minimum mass of the sample, all of which passes the 2 in (50 mm) sieve and is retained on the No. 4 (4.75 mm) sieve, shall be as set out in the following **Table 1**:

Table 1
Minimum Sample Size for Coarse Aggregate

Sieve Size	Minimum Mass of Samples (g)
1 1/2 in (37.5 mm) or more	5,000
1 in (25.0 mm)	4,000
3/4 in (19.0 mm)	3,000
1/2 in (12.5 mm) or less	2,000

NOTE: To select the sample size, use the largest sieve on which 5% or more of the material is specified to be retained.

3.2.1.2. Thoroughly wash¹ the sample over the No. 4 (4.75 mm) sieve to remove dust and other adherent coatings.

3.2.1.3. Dry the sample to a constant mass in the oven at a constant temperature of $230 \pm 9^\circ\text{F}$ ($110 \pm 5^\circ\text{C}$).

NOTE: If the absorption and specific gravity values will be used as a basis for the design of concrete mixes where aggregates are used in a moist condition, this drying procedure may be eliminated. For an aggregate that has been in contact with water and that has free moisture on the particle surfaces, the percentage of free moisture can be determined by deducting the absorption from the total moisture content determined by **KT-11 Section 5.1**. Free moisture can also be calculated as described in **KT-24 Section 6**.

3.2.2. Procedure

3.2.2.1. Immerse the sample in water² and stir vigorously. Soak for a period of 24 ± 4 hours.

3.2.2.2. Remove the sample from the water and bring to a saturated surface-dry condition by rolling the sample in a dampened, absorbent cloth. (For the purpose of this test, a saturated surface-dry condition of the aggregate has been reached when the particle surface appears to be moist but not shiny.)

3.2.2.3. Weigh the sample immediately after obtaining the saturated surface-dry condition. Record this value as "B". All masses determined in this test shall be to the nearest 1 g or 0.1% of the sample mass, whichever is greater.

¹ **AASHTO T 85** requires dry sieving and then thoroughly wash to remove dust or other coatings from the surface.

² **AASHTO T 85** requires the sample to be dried to constant mass prior to immersing in water for a period of 15 to 19 hours.

3.2.2.4. Immediately after obtaining the saturated surface-dry mass, immerse the sample in water, stir to remove any entrapped air and weigh. Record this value as “C”. The water temperature shall be $77 \pm 2^\circ\text{F}$ ($25 \pm 1^\circ\text{C}$)³.

3.2.2.5. Dry the sample to a constant mass at a temperature of $230 \pm 9^\circ\text{F}$ ($110 \pm 5^\circ\text{C}$).

3.2.2.6. Cool the sample at room temperature, until aggregate has cooled to a temperature that is comfortable to handle and determine the mass. Record this value as “A”.

3.3. Calculations

Where: A= Mass of oven-dry sample in air, g
 B= Mass of surface-dry sample in air, g
 C= Mass of saturated sample in water, g

3.3.1. Bulk Specific Gravity:

$$\frac{A}{B - C}$$

3.3.2. Bulk Specific Gravity Saturated Surface-Dry Basis:

$$\frac{B}{B - C}$$

3.3.3. Apparent Specific Gravity:

$$\frac{A}{A - C}$$

3.3.4. Absorption (%):

$$\frac{100 (B - A)}{A}$$

4. PROCEDURE II: FINE AGGREGATE

4.1. Apparatus

4.1.1. The balance shall conform to the requirements of **Part V, 5.9; Sampling and Test Methods Foreword**, Class G2.

4.1.2. Volumetric flask of known mass having a minimum capacity of 500mL and calibrated by the manufacturer to within:

- 0.20mL at 68°F (20°C) for a 500mL flask.
- 0.30mL at 68°F (20°C) for a 1000mL flask.

³ **AASHTO T 85** requires the water temperature to be $23 \pm 1.7^\circ\text{C}$ ($73.4 \pm 3^\circ\text{F}$). Changing the temperature to $25 \pm 1^\circ\text{C}$ ($77 \pm 2^\circ\text{F}$) establishes a uniform temperature requirement on all water bath test-related procedures.

4.1.3. Not less than two drying pans with a bottom surface of the pan that will have no effect on the material and results but should allow for the presence of free moisture to be observed. A worn oxidized surface has been known to work well in showing the presence of free moisture. Other surfaces such as a worn aluminum pan or galvanized pan may also work. The pan should be flat, dry, clean and have a dull, non-absorbent surface.

4.1.4. Drying oven capable of maintaining a uniform temperature of $230 \pm 9^\circ\text{F}$ ($110 \pm 5^\circ\text{C}$).

4.1.5. Water bath having a capacity of at least 2 gal (8 L) maintained at a temperature of $77 \pm 2^\circ\text{F}$ ($25 \pm 1^\circ\text{C}$) and a depth approximately equal to or above the height of the bowl of the volumetric flask.

4.1.6. Standard No. 4 (4.75 mm) sieve meeting requirements of **ASTM E11**.

4.1.7. Standard No.100 (150 μm) sieve meeting requirements of **ASTM E11**.

4.2. Test Method

4.2.1. Sample Preparation: This test is conducted on that portion of aggregate passing the No. 4 (4.75 mm) and retained on the No.100 (150 μm) sieve.

4.2.1.1. Select a portion of the aggregate by splitting or quartering as established in **KT-01, Section 4**. The portion selected should be of sufficient size to yield a sample weighing approximately 1,000 g all of which passes the No. 4 (4.75 mm) sieve and retained on the No. 100 (150 μm) sieve.

4.2.1.2. Screen the portion selected over the No. 4 (4.75 mm) sieve and discard all material retained on that sieve.

4.2.1.3. Wash the minus No. 4 (4.75 mm) material [material passing the No. 4 (4.75mm) sieve] over the No. 100 (150 μm) sieve to remove dust.

4.2.1.4. Dry the plus No. 100 (150 μm) material [material retained on the No. 100 (150 μm) sieve] to a constant mass in the oven.

NOTE: If the absorption and specific gravity values will be used as a basis for the design of concrete mixes where aggregates are used in a moist condition, this drying procedure may be eliminated. For an aggregate that has been in contact with water and that has free moisture on the particle surfaces, the percentage of free moisture can be determined by deducting the absorption from the total moisture content determined by **KT-11 Section 5.1**. Free moisture can also be calculated as described in **KT-24 Section 6**.

4.2.2. Procedure

4.2.2.1. Immerse the sample in water and stir vigorously. Soak for a period of 24 ± 4 hours.

4.2.2.2. Remove the sample from the water and bring it to a saturated surface-dry condition⁴. The procedure to be used to obtain the surface-dry condition is as follows:

⁴ **AASHTO T 84 Section 7.2.1** uses the cone test for determining SSD condition. Under **NOTE 4 (2) Provisional Surface Test**, the use of alternative surfaces are permitted and represents the method presented in **Section 4.2.2**.

4.2.2.2.1. Place the saturated sample in a drying pan and allow to dry in air for a short time. Stir the sample regularly to ensure uniform drying.

4.2.2.2.2. Transfer the sample to another drying pan. The surface of the pan may be of any surface that will have no effect on the material and results but should allow for the presence of free moisture to be observed.

4.2.2.2.3. Stir the sample and check for the presence of free moisture as indicated by a presence of moisture on the bottom surface of the pan. This can typically be seen by a change in color or the presence of a sheen of moisture on the surface of the pan.

NOTE: The first check should be conducted when there is some free moisture on the surface of the aggregate particles to ensure that a saturated surface-dry condition has not been passed. If no moisture is present, it is likely the SSD condition is passed, and the test must be restarted.

4.2.2.2.4. Stir the sample regularly and transfer it frequently from pan to pan until a saturated surface-dry condition is reached as indicated by the absence of free moisture on the bottom of the pan.

4.2.2.2.5. Determine the mass of the empty flask. Record the value as “F”.

4.2.2.3. Immediately split out and weigh a sample of the saturated surface-dry material weighing not less than 500 g. Record this value as “B”. Place the sample in the flask.

4.2.2.4. Fill the flask to a level slightly below the calibration mark with water at a temperature of $77 \pm 2^{\circ}\text{F}$ ($25 \pm 1^{\circ}\text{C}$).

4.2.2.5. Rotate the flask in an inclined position to eliminate all air bubbles. Do not shake. Allow the flask to sit for several minutes then roll flask again. Continue the process until there are no visible air bubbles present.

NOTE: Bubbles or foam may be dispelled by touching them carefully with a hot wire or the tip of a paper towel.

4.2.2.6. Place the flask in the water bath until the temperature of the material inside the flask is the same as that of the water bath.

4.2.2.7. Fill the flask to the calibrated mark, remove from the water bath and wipe all moisture from the outside surface.

4.2.2.8. Weigh the flask and its contents to the nearest 0.1 g. Record the value as “K”.

4.2.2.9. Remove the aggregate from the flask and dry to a constant mass in the oven at a temperature of $230 \pm 9^{\circ}\text{F}$ ($110 \pm 5^{\circ}\text{C}$).

4.2.2.10. Cool the sample to room temperature and weigh. Record the value as “A”.

4.3. Flask Verification – Perform minimum every 12 months - Determine the mass of flask filled to the calibration line with water at 77°F (25°C) and subtract the mass of the flask to determine the mass of water the flask will hold. Record this value as “C”. This step need not be performed for every test but must be done a minimum of once every 12 months.

4.4. Calculations

4.4.1. $W = K - (F + B)$

4.4.2. Bulk Specific Gravity:

$$\frac{A}{C - W}$$

4.4.3. Bulk Specific Gravity (Saturated Surface-Dry Basis):

$$\frac{B}{C - W}$$

4.4.4. Apparent Specific Gravity:

$$\frac{A}{(C - W) - (B - A)}$$

4.4.5. Absorption (%):

$$\frac{100 (B - A)}{A}$$

Where: W= Mass of water added to the flask, g
 F= Mass of empty flask, g
 K= Mass of flask, plus sample, plus water (See step in **Section 4.2.2.8** above), g
 A= Mass of oven-dry sample in air, g
 B= Mass of saturated surface-dry sample in air, g
 C= Mass of water the flask will hold filled to the calibration line at 77°F (25°C)

5. REPORT

5.1. Record the specific gravities to the nearest 0.001. Record the absorption to the nearest 0.01%. Report all specific gravities to the nearest 0.001 and indicate the type of specific gravity. Report the absorption result to the nearest 0.1%.

6. PRECISION

6.1. The estimates of precision of this test method (listed in **Table 2**) are based on results from the **AASHTO Materials Reference Sample Program** with testing conducted by **AASHTO, T 84** and **T 85**, and **ASTM, C128** and **C670**. The significant difference between the methods is that ASTM requires a saturation period of 24 ± 4 hours, and AASHTO requires a saturation period of 15 to 19 hours. This difference has been found to have an insignificant effect on the precision indices.

**Table 2
Precision for Specific Gravities
and Absorption of Aggregates**

	Coarse Aggregate		Single Operator Precision	Fine Aggregate	
	1S	D2S		1S	D2S
Single Operator Precision					
Bulk Specific Gravity (Dry)	0.009	0.025	Bulk Specific Gravity (Dry)	0.011	0.032
Bulk Specific Gravity (SSD)	0.007	0.020	Bulk Specific Gravity (SSD)	0.0095	0.027
App. Specific Gravity	0.007	0.020	App. Specific Gravity	0.0095	0.027
Absorption percent	0.088	0.25	Absorption percent	0.11	0.31
Multilaboratory Precision			Multilaboratory Precision		
Bulk Specific Gravity (Dry)	1S	D2S	Bulk Specific Gravity (Dry)	1S	D2S
Bulk Specific Gravity (Dry)	0.013	0.038	Bulk Specific Gravity (Dry)	0.023	0.066
Bulk Specific Gravity (SSD)	0.011	0.032	Bulk Specific Gravity (SSD)	0.020	0.056
App. Specific Gravity	0.011	0.032	App. Specific Gravity	0.020	0.056
Absorption percent	0.145	0.41	Absorption percent	0.23	0.66

7. ADDENDUM – SUPPLEMENTAL CALCULATION TO COMBINE AGGREGATE ABSORPTION

7.1. In a few special cases the specifications have an absorption requirement on each individual source. Procedures I and II are both used and the combined aggregate absorption must be calculated. (This calculation is not to be used when the specifications have an absorption requirement by Procedure I and/or Procedure II.

7.2. Absorption of the individual source equals:

Combined Absorption, A_{co} (%):

$$\frac{(AbS_c)(\%C) + (AbS_f)(\%I)}{100}$$

Where: A_{co} = Combined Absorption, %
 AbS_c = Absorption, Proc. I, %
 AbS_f = Absorption, Proc. II, %
 $\%C$ = Percent plus No. 4 (4.75 mm) in each individual source
 $\%I$ = Percent minus No. 4 (4.75 mm) in each individual source

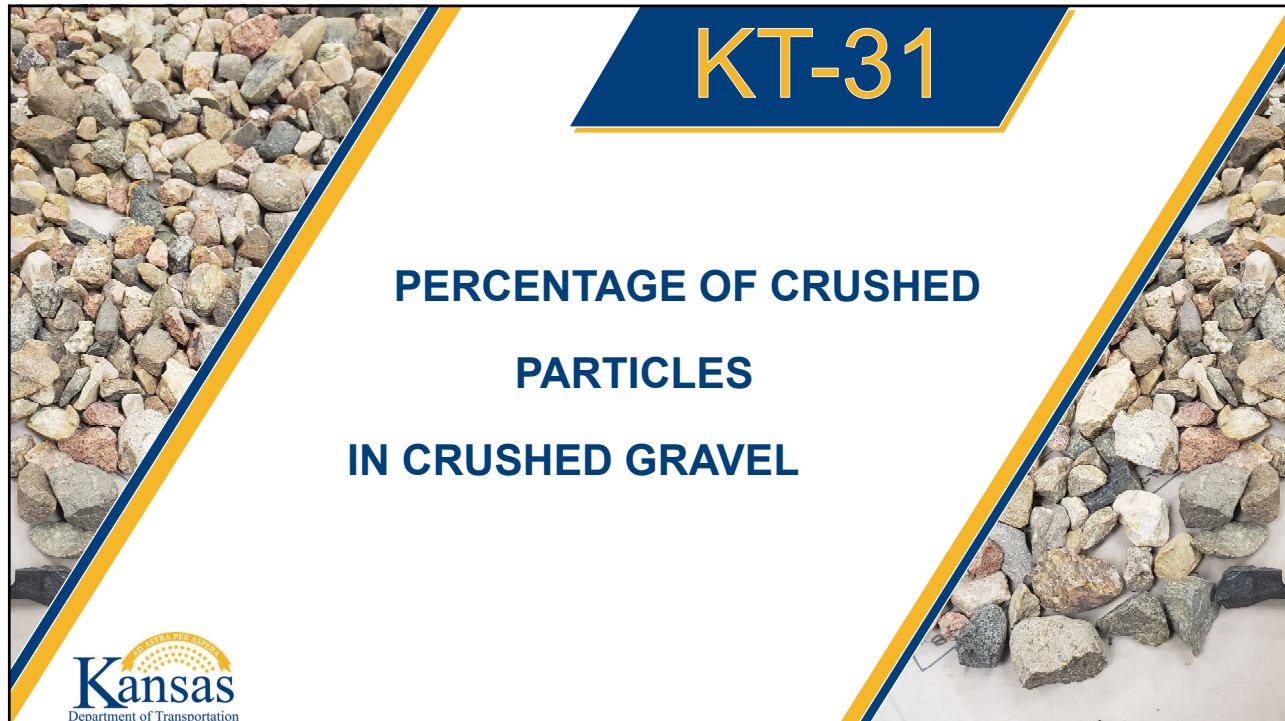

1

KT-31 Determination of Percentage of Crushed Particles in Crushed Gravel



Scope

- ❖ Determining the percent, by mass, of particles which through visual observation show characteristics of a crushed particle

2

KT-31 Determination of Percentage of Crushed Particles in Crushed Gravel

Reference Documents

- *Part V, 5.9; Sampling and Test Methods Foreword*
- *KT-1; Sampling and Splitting of Aggregates*
- *AASHTO M 92; Wire-Cloth Sieves for Testing Purposes*

3

KT-31 Determination of Percentage of Crushed Particles in Crushed Gravel

Apparatus

- ❖ Balance, G5 classification when nominal max aggregate size (one size larger than the first sieve to retain more than 10% of the material) is 1 ½" and G2 classification for all others
- ❖ Sieves; 1 ½" to No. 4
- ❖ Drying Pans
- ❖ Oven capable of maintaining a uniform temperature of 230 ± 9°F (110 ± 5°C)

4

KT-31 Determination of Percentage of Crushed Particles in Crushed Gravel

Sample Preparation

- ❖ Split and quarter (according to KT-1) a material sample larger than the sizes listed in Table 1 to procure a sample of sufficient dry mass
- ❖ Screen and wash the sample over the No. 4 sieve discarding any material that passes (wash sample until water is clear or otherwise acceptable)
- ❖ Dry the sample to a constant mass (what is constant mass?)
- ❖ Consult Table 1 to verify the sample size required based on nominal maximum aggregate size

5

KT-31 Determination of Percentage of Crushed Particles in Crushed Gravel

Test Procedure:

Only One or More Fractured Faces

- ❖ Weigh the sample retained on the No. 4 sieve to the nearest gram
- ❖ Record this mass as the original dry mass (**ODM**)
- ❖ Spread the weighed material on a clean, flat surface for examination



6

KT-31 Determination of Percentage of Crushed Particles in Crushed Gravel

Test Procedure:

Only One or More Fractured Faces

- ❖ Separate crushed from uncrushed particles where any particle with at least one **fractured face** is considered a **crushed particle**

IMPORTANT

Crushed particles are defined as having **25% or more fractured face**

Fractured faces are **angular, rough, or broken surfaces on the particle**



7

KT-31 Determination of Percentage of Crushed Particles in Crushed Gravel

Calculations

For specifications requiring determination of only one or more fractured faces

$$\text{Percent Crushed Particles} = \frac{100(\text{Mass of Crushed Particles})}{ODM}$$

8

KT-31 Determination of Percentage of Crushed Particles in Crushed Gravel

Calculations

For specifications requiring determination of one or more and two or more fractured faces

$$\text{Percent Crushed Particles} = \frac{100(F_1 + F_2)}{ODM}$$

with one or more fractured faces

$$\text{Percent Crushed Particles} = \frac{100(F_2)}{ODM}$$

with two or more fractured faces

5.9.31 DETERMINATION OF PERCENTAGE OF CRUSHED PARTICLES IN CRUSHED GRAVEL
(Kansas Test Method KT-31) AKA: COARSE AGGREGATE ANGULARITY

1. SCOPE

This method of test covers the procedure for determining the percent, by mass, of particles, which by visual inspection, exhibit characteristics of crushed aggregate. **KT-31** reflects testing procedures found in ASTM D5821.

2. REFERENCED DOCUMENTS

2.1. Part V, 5.9; Sampling and Test Methods Foreword

2.2 KT-01; Sampling and Splitting of Aggregates

2.3. ASTM E11; Standard Specification for Woven Wire Test Sieve Cloth and Test Sieves

3. APPARATUS

3.1. The balance shall conform to the requirements of **Part V, 5.9; Sampling and Test Methods Foreword**, for the class of general purpose balance required for the principal sample mass of the sample being tested.

3.2. Sieves meeting **ASTM E11** of appropriate sizes.

3.3. Drying Pans.

3.4. Oven capable of maintaining a uniform temperature of $230 \pm 9^\circ\text{F}$ ($110 \pm 5^\circ\text{C}$).

4. SAMPLE PREPARATION

4.1. Obtain the test sample by quartering or splitting according to **KT-01** from material which has been thoroughly mixed. The sample shall be of sufficient size to yield the minimum dry mass shown in **Table 1** after washing over the No. 4 (4.75 mm) sieve. Screen the sample over a No. 4 (4.75 mm) sieve and discard all material passing the sieve. Wash the retained material over a No. 4 (4.75 mm) sieve and dry the sample to a constant mass at $230 \pm 9^\circ\text{F}$ ($110 \pm 5^\circ\text{C}$).

TABLE 1

Nominal Maximum Aggregate Size		Minimum Dry Sample Mass
1 ½" (37.5 mm)		6 lb (2500 g)
1" (25.0 mm)		3.5 lb (1500 g)
¾" (19.0 mm)		2.2 lb (1000 g)
½" (12.5 mm)		1.5 lb (700 g)
⅜" (9.5 mm)		0.9 lb (400 g)
No. 4 (4.75 mm)		0.5 lb (200 g)

NOTE: Nominal maximum aggregate size is one size larger than the first sieve to retain more than 10%.

5. TEST PROCEDURE

NOTE: For test procedures requiring the determination of two or more fractured faces go to Section 6. of this test method.

5.1. Weigh the material retained on the No. 4 (4.75 mm) sieve to the nearest gram. Record this mass as the original dry mass.

5.2. Spread the material in a thin layer on a clean flat surface so that each particle can be examined.

5.3. Separate the crushed particles from uncrushed particles. Any particle appearing to have one or more fractured faces shall be considered a crushed particle.

NOTE: Crushed particles are defined as 25% or more of the particle having a fractured face. A fractured face is defined as an angular, rough or broken surface of an aggregate particle. (See Figure 1)

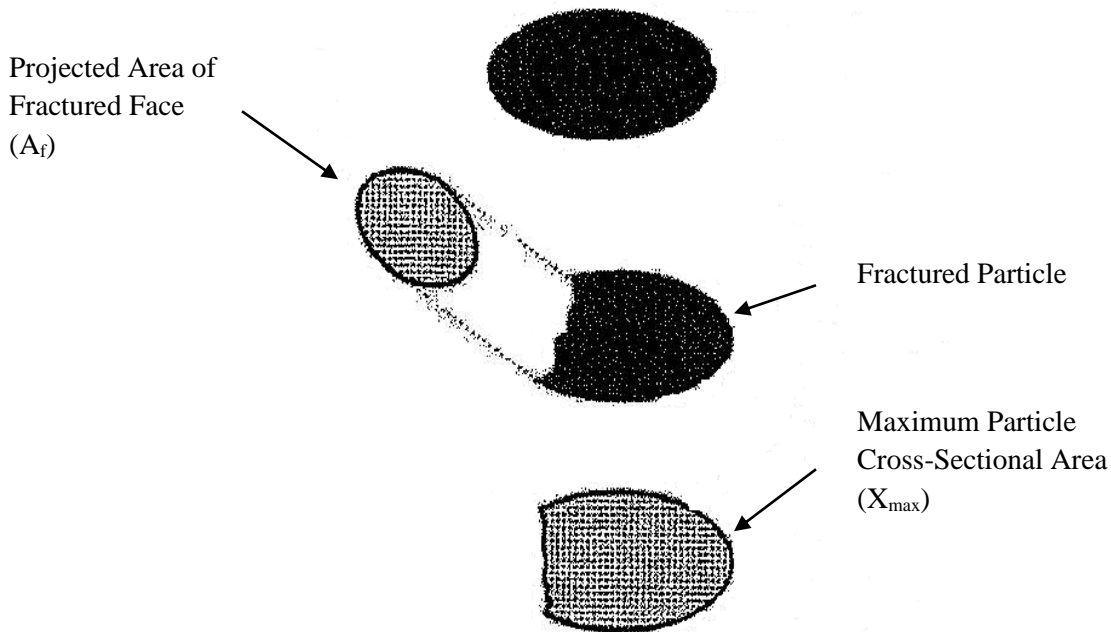

Figure 1
Schematic of a Fractured Particle with One Fractured Face

A face will be considered a “Fractured Face” only if $A_f \geq 0.25 X_{max}$

5.4 Determine the mass to the nearest gram and record as mass of crushed particles.

6. TEST PROCEDURE FOR SPECIFICATIONS REQUIRING DETERMINATION OF ONE OR MORE AND TWO OR MORE FRACTURED FACES

6.1. Weigh the material retained on the No. 4 (4.75 mm) sieve to the nearest gram. Record this mass as the original dry mass.

6.2. Spread the material in a thin layer on a clean flat surface so that each particle can be examined.

6.3. Separate the crushed particles into three piles; uncrushed particles, particles with two or more fractured faces and particles with one fractured face.

NOTE: Crushed particles are defined as 25% or more of the particle having a fractured face. A fractured face is defined as an angular, rough or broken surface of an aggregate particle. (See **Figure 1**)

6.4. Determine the mass to the nearest gram of each pile with crushed faces and record as:

F₁=Mass of particles with one fractured face

F₂=Mass of particles with two or more fractured faces

7. CALCULATIONS

7.1. For specifications requiring determination of only one or more fractured faces:

$$\text{Percent Crushed Particles} = \frac{100(\text{Mass of Crushed Particles})}{\text{Original Dry Mass}}$$

7.2. For specifications requiring determination of one or more and two or more fractured faces:

NOTE: Skip **Sect. 7.2.** for specifications not requiring the determination of two or more fractured faces.

Compute the percentage of crushed particles for specifications requiring the determination of two or more fractured faces using the following formulas:

$$\text{Percent Crushed Particles with 1 or more Fractured Faces} = \frac{100(F_1 + F_2)}{\text{Original Dry Mass}}$$

$$\text{Percent Crushed Particles with 2 or more Fractured Faces} = \frac{100(F_2)}{\text{Original Dry Mass}}$$

8. REPORT

8.1. Record to the nearest 0.1% of crushed particles. Report the results to 1% crushed particles.



1

KT-55 Plastic Fines in Combined Aggregates by Use of the Sand Equivalent Test

Scope

- ❖ Serves as a rapid test to show the relative proportions of fine dust or claylike material in minus No. 4 combined aggregates
- ❖ These fines are detrimental to the performance of aggregates, so knowing the relative amount present is important to design and meet compliance

2

KT-55 Plastic Fines in Combined Aggregates by Use of the Sand Equivalent Test

Reference Documents

- *AASHTO T 176; Plastic Fines in Graded Aggregates and Soils by Use of the Sand Equivalent Test*

3

KT-55 Plastic Fines in Combined Aggregates by Use of the Sand Equivalent Test

Apparatus

- ❖ Graduated plastic cylinder, rubber stopper, irrigator tube, weighted foot assembly and siphon assembly
- ❖ See AASHTO T 176, Section 4.1 for specifications and dimensions of the assemblies
- ❖ Straightedge or spatula, suitable for striking off the excess material from the tin measure
- ❖ Oven capable of maintaining a uniform temperature of $230 \pm 9^{\circ}\text{F}$ ($110 \pm 5^{\circ}\text{C}$)
- ❖ Fit siphon assembly to a 1 gallon bottle of working calcium chloride solution placed on a shelf 36 ± 1 in above the work surface

4

KT-55 Plastic Fines in Combined Aggregates by Use of the Sand Equivalent Test

Apparatus Cont.

- ❖ 3 oz tinned box approximately 2.25" in diameter, with Gill style cover
- ❖ Wide mouth funnel approximately 4" in diameter
- ❖ A clock or watch reading in minutes and seconds
- ❖ A mechanical shaker as described in *AASHTO T 176, Section 4.6*
 - Prior to use of the shaker, fasten the mechanical sand equivalent shaker securely and firmly to a firm and level mount

5

KT-55 Plastic Fines in Combined Aggregates by Use of the Sand Equivalent Test

Apparatus Cont.

Stock calcium chloride solution:

1 lb technical grade Anhydrous Calcium Chloride
 2050 g USP Glycerin
 47 g Formaldehyde (40% solution)



Procedure for generating stock calcium chloride solution:

1. Dissolve calcium chloride in ½ gal of distilled water
2. Cool the solution and then filter it through Whatman No. 12 or equivalent filter paper
3. Add glycerin and formaldehyde to the filtered solution, mix well, and dilute to 1 gal with distilled water

6

KT-55 Plastic Fines in Combined Aggregates by Use of the Sand Equivalent Test

Apparatus Cont.

Procedure for generating working calcium chloride solution:

1. Dilute 3 ± 0.2 oz (85 ± 5 mL) of the stock calcium chloride solution to 1 gal with water
2. Use distilled or demineralized water for the normal preparation of the working solution
3. After an age of **30 days** the working solutions should be discarded



7

KT-55 Plastic Fines in Combined Aggregates by Use of the Sand Equivalent Test

Control

Maintain the temperature of the working solution at $72 \pm 5^\circ\text{F}$ ($22 \pm 3^\circ\text{C}$) during the test
If in the field the temperatures cannot be maintained, submit reference samples to district labs for comparison
Temperature correction factors can be made for each combined aggregate being tested

8

KT-55 Plastic Fines in Combined Aggregates by Use of the Sand Equivalent Test

Control

Perform test in a location with no vibrations
Vibrations may alter the results by upsetting the settling of the material
Do not expose the cylinders to sunlight
Keep the assemblies and equipment clean and free of organics
Section 4.4 provides a detailed cleaning procedure

9

KT-55 Plastic Fines in Combined Aggregates by Use of the Sand Equivalent Test

Control

The irrigator tube can be plugged by sand
If the opening cannot be opened by any other means, use a pin or sharp object to force the obstruction out without enlarging the opening

10

KT-55 Plastic Fines in Combined Aggregates by Use of the Sand Equivalent Test

Sample Preparation

Only aggregate passing the No. 4 sieve is used in this test so all material retained on the No. 4 is discarded
Pulverize the aggregate in fine-grained soils to pass the No. 4 sieve
Clean all fines from the fine-grained soil particles retained on the No. 4 and include those particles with the material that passed the No. 4

11

KT-55 Plastic Fines in Combined Aggregates by Use of the Sand Equivalent Test

Sample Preparation

Split or quarter a sample large enough to yield four 3 oz (85 mL) tin measures of material passing the No. 4 sieve
Take care to get samples truly representative of the original
Dampen the sample if necessary to avoid losses or segregation

12

KT-55 Plastic Fines in Combined Aggregates by Use of the Sand Equivalent Test

Sample Preparation

Prepare two test samples:

Fill two 3 oz tin measures with the material passing the No. 4 sieve (See Section 5.3.1)

While filling the measure, tap the bottom edge of the tin on a hard surface to consolidate the material and allow the max amount to be placed in the tin

Strike off the tin measure with a spatula or straightedge

Dry the test sample to constant mass (what is constant mass?) at $230 \pm 9^{\circ}\text{F}$ ($110 \pm 5^{\circ}\text{C}$) and let cool to room temperature before testing

13

KT-55 Plastic Fines in Combined Aggregates by Use of the Sand Equivalent Test

Test Procedure

For Each Test Sample:

Siphon 4 ± 0.1 in (101.6 ± 2.5 mm) of working calcium chloride solution into the plastic cylinder

Pour the prepared test sample from the measuring tin into the plastic cylinder using a funnel to avoid losses

Tap the bottom of the cylinder sharply on the heel of the hand several times to release air bubbles and promote wetting of the sample

14

KT-55 Plastic Fines in Combined Aggregates by Use of the Sand Equivalent Test

Test Procedure

After wetting the sample in the cylinder allow the cylinder to sit undisturbed for 10 ± 1 minutes
After the 10 ± 1 min soaking period, stopper the cylinder and then loosen the material on the bottom by partially inverting the cylinder and shaking it
After loosening the material, place the stoppered cylinder in the mechanical shaker and secure
Set the timer to 45 sec and start the shaker

15

KT-55 Plastic Fines in Combined Aggregates by Use of the Sand Equivalent Test

Test Procedure

After mechanical shaking, set the cylinder upright on work surface and remove stopper
Insert the irrigator tube in the cylinder and rinse material from the walls
Force the tube through the material to the bottom of the cylinder by gently stabbing and twisting the tube while working solution flows
This procedure forces fine material into suspension above the coarser material

16

KT-55 Plastic Fines in Combined Aggregates by Use of the Sand Equivalent Test

Test Procedure

Continue the stabbing and twisting motion until the cylinder is filled to the 15 in mark
Raise the tube slowly without shutting off the flow so the liquid level stays at the 15 in mark
Regulate the flow just before the irrigator is entirely withdrawn and remove or add working solution to adjust the level to 15 in

17

KT-55 Plastic Fines in Combined Aggregates by Use of the Sand Equivalent Test

Test Procedure

Allow the cylinder to stand undisturbed for 20 minutes \pm 15 seconds
Begin timing immediately after removing the irrigator
After the 20 minutes, read and record the top of the clay suspension this is known as the "clay reading"
If no clear distinction of a line for the "clay reading" forms after 20 minutes then allow the sample to stand until a reading can be taken

18

KT-55 Plastic Fines in Combined Aggregates by Use of the Sand Equivalent Test

Test Procedure

However, if the total time the sample sits undisturbed exceeds 30 minutes and there is no clear demarcation, the test has to be rerun using 3 individual samples of the same material
Read and record the clay column height of the sample with the shortest sedimentation period only

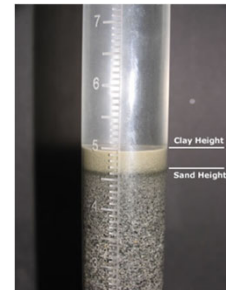

19

KT-55 Plastic Fines in Combined Aggregates by Use of the Sand Equivalent Test

Test Procedure

Find and record the "sand reading" after obtaining the clay reading
This reading is found by lowering the weighted foot into the cylinder slowly towards the sand
Do not allow the indicator to touch the mouth of the cylinder while being lowered
As the weighted foot comes to a rest on the sand, tip the assembly toward the graduations on the cylinder until the indicator touches the inside of the cylinder



20

KT-55 Plastic Fines in Combined Aggregates by Use of the Sand Equivalent Test

Test Procedure

After tipping the assembly, subtract 10 in from the level reached by the top of the indicator and this represents the sand reading
 If the reading falls between the 0.1 in graduations, the higher graduation should be recorded
 See 6.9 for example

21

KT-55 Plastic Fines in Combined Aggregates by Use of the Sand Equivalent Test

Calculations

Sand equivalent (SE) value needs to be calculated to the nearest 0.1

$$SE = 100 * ((Sand Reading) / (Clay Reading))$$

If the SE is not a whole number, it needs to be reported as the next higher whole number

See 7.2 for example

Recording

Record and report to the whole number

Always round up

22

5.9.55 PLASTIC FINES IN COMBINED AGGREGATES BY USE OF THE SAND EQUIVALENT TEST (Kansas Test Method KT-55)

1. SCOPE

This test is intended to serve as a rapid test to show the relative proportions of fine dust or claylike material in minus No. 4 (4.75 mm) combined aggregates. **KT-55** reflects testing procedures found in **AASHTO T 176**.

2. REFERENCED DOCUMENTS

2.1. AASHTO T 176; Plastic Fines in Graded Aggregates and Soils by Use of the Sand Equivalent Test

3. APPARATUS

3.1. A graduated plastic cylinder, rubber stopper, irrigator tube, weighted foot assembly and siphon assembly, all conforming to their respective specifications and dimensions described in **AASHTO T 176, Section 4.1**. Fit the siphon assembly to a 1 gal (4 L) bottle of working calcium chloride solution (see **Section 3.7** of this test method) placed on a shelf 36 ± 1 in (915 ± 25 mm) above the work surface.

3.2. A 3 ± 0.2 oz (85 ± 5 mL) tinned box approximately 2.25 in (57 mm) in diameter, with Gill style cover.

3.3. A wide mouth funnel approximately 4 in (100 mm) in diameter.

3.4. A clock or watch reading in minutes and seconds.

3.5. A mechanical shaker as described in **AASHTO T 176, Section 4.6**. Prior to use, fasten the mechanical sand equivalent shaker securely to a firm and level mount.

3.6. Stock calcium chloride solution: Prepare the stock calcium chloride solution as follows:

1 lb (454 g) technical grade Anhydrous Calcium Chloride
2050 g (1640 mL) USP Glycerin
47 g (45 mL) Formaldehyde (40% solution)

3.6.1. Dissolve the calcium chloride in 1/2 gal (1.89 L) of distilled water. Cool the solution and then filter it through Whatman No. 12 or equivalent paper. Add the glycerin and formaldehyde to the filtered solution, mix well, and dilute to 1 gal (3.78 L) with distilled water.

3.7. Working calcium chloride solution: Prepare the working calcium chloride by diluting 3 ± 0.2 oz (85 ± 5 mL) of the stock calcium chloride solution to 1 gal (3.78 L) with water. Use distilled or demineralized water for the normal preparation of the working solution. Working solutions more than 30 days old shall be discarded.

3.8. A straightedge or spatula, suitable for striking off the excess material from the tin measure.

3.9. A thermostatically controlled drying oven capable of maintaining a temperature of $230 \pm 9^\circ\text{F}$ ($110 \pm 5^\circ\text{C}$).

4. CONTROL

4.1. Maintain the temperature of the working solution at $72 \pm 5^{\circ}\text{F}$ ($22 \pm 3^{\circ}\text{C}$) during the performance of this test. If field conditions prevent temperatures from staying within this temperature range, submit frequent referee samples to the district laboratory for comparison. Temperature correction factors can also be established for each combined aggregate being tested.

4.2. Perform the test in a location free of vibrations; vibrations may cause the suspended material to settle at a rate greater than normal.

4.3. Do not expose the plastic cylinders to direct sunlight any more than is necessary.

4.4. To remove organic growth from the working calcium chloride solution container and from the inside of the flexible tubing and irrigator tube, prepare a cleaning solvent by diluting sodium hypochlorite with an equal quantity of water. Fill the solution container with the prepared cleaning solvent. Allow about a liter of the cleaning solvent to flow through the siphon assembly and irrigator tube, allow to stand overnight. After soaking, allow the cleaning solvent to flow out through the siphon assembly and irrigator tube. Remove the siphon assembly from the solution container and rinse both with clear water. The irrigator tube and siphon assembly can be rinsed easily by attaching a hose between the tip of the irrigator tube and water faucet and backwashing fresh water through the tube.

4.5. Occasionally the holes in the tip of the irrigator tube may become clogged by a particle of sand. If the obstruction cannot be freed by any other method, use a pin or other sharp object to force it out, using extreme care not to enlarge the size of the opening.

5. SAMPLE PREPARATION

5.1. Perform the sand equivalent test on combined aggregate materials passing the No. 4 (4.75 mm) sieve. Pulverize all aggregate of fine-grained soil materials to pass the No. 4 (4.75 mm) sieve, and clean all fines from the particles retained on the No. 4 (4.75 mm) sieve and include with the material passing the No. 4 (4.75 mm) sieve.

5.2. Split or quarter enough of the original sample to yield slightly more than four 3 oz (85 mL) tin measures of material passing the No. 4 (4.75 mm) sieve. Use extreme care to obtain a truly representative portion of the original sample. Dampen the material to avoid loss or segregation of the fines if necessary.

5.3. Prepare two test samples using the following method.

5.3.1. Split or quarter enough material from the portion passing the No. 4 (4.75 mm) sieve to fill the 3 oz. (85 mL) tin measure so it is slightly rounded above the brim. While filling the measure, tap the bottom edge of the tin on the work table or other hard surface to cause consolidation of the material and allow the maximum amount to be placed in the tin. Strike off the tin measure level full with a spatula or straightedge.

5.3.2. Dry the test sample to constant mass at $230 \pm 9^{\circ}\text{F}$ ($110 \pm 5^{\circ}\text{C}$), cool to room temperature before testing.

6. PROCEDURE

6.1. For each test sample: Siphon 4 ± 0.1 in (101.6 ± 2.5 mm) of working calcium chloride solution into the plastic cylinder. Pour the prepared test sample from the measuring tin into the plastic cylinder using the funnel to avoid spillage. Tap the bottom of the cylinder sharply on the heel of the hand several times to release air bubbles and to promote thorough wetting of the sample.

6.2. Allow the wetted sample to stand undisturbed for 10 ± 1 minutes. At the end of the 10 minute soaking period, stopper the cylinder, then loosen the material from the bottom by partially inverting the cylinder and shaking it simultaneously.

6.3. After loosening the material from the bottom of the cylinder, place the stoppered cylinder in the mechanical¹ sand equivalent shaker and secure. Make sure the timer is set for 45 seconds then turn the shaker on.

6.4. Following the shaking operation, set the cylinder upright on the work surface and remove the stopper.

6.5. Insert the irrigator tube in the cylinder and rinse material from the cylinder walls as the irrigator is lowered. Force the irrigator through the material to the bottom of the cylinder by applying a gentle stabbing and twisting action while the working solution flows from the irrigator tip. This flushes the fine material into suspension above the coarser sand particles. Continue to apply the stabbing and twisting action while flushing the fines upward until the cylinder is filled to the 15 in (381 mm) mark. Then raise the irrigator slowly without shutting off the flow so that the liquid level is maintained at 15 in (381 mm) while the irrigator is being withdrawn. Regulate the flow just before the irrigator is entirely withdrawn and adjust the final level to 15 in (381 mm).

6.6. Allow the cylinder and contents to stand undisturbed for 20 minutes \pm 15 seconds. Start the timing immediately after withdrawing the irrigator tube.

6.7. At the end of the 20-minute sedimentation period, read and record the top level of the clay suspension. This is referred to as the “clay reading”. If no clear line of demarcation has formed at the end of the specified 20-minute sedimentation period, allow the sample to stand undisturbed until a clay reading can be obtained, then immediately read and record the top level of the clay suspension and total sedimentation time. If the total sedimentation time exceeds 30 minutes, rerun the test using three individual samples of the same material. Read and record the clay column height of that sample requiring the shortest sedimentation period only.

6.8. Obtain the ‘sand reading’ after the clay reading has been taken. The sand reading is determined by placing the weighted foot assembly over the cylinder and gently lowering the assembly toward the sand. Do not allow the indicator to hit the mouth of the cylinder as the assembly is being lowered. As the weighted foot comes to rest on the sand, tip the assembly toward the graduations on the cylinder until the indicator touches the inside of the cylinder. Subtract 10 in (254 mm) from the level indicated by the extreme top edge of the indicator and record this value as the sand reading.

6.9. If the clay or sand readings fall between the 0.1 in (2.5 mm) graduations, record the level of the higher graduation as the reading. For example, a clay reading of 7.95 in (199 mm) would be recorded as 8.0 in (200 mm), and a sand reading of 3.32 in (83 mm) would be recorded as 3.4 in (85 mm).

¹ AASHTO T 176 Section 8.4.2. and 8.4.3 provides alternative means of the sample; the Manual and Hand Method. The alternatives are not options under **KT-55**.

7. CALCULATIONS

7.1. Calculate the sand equivalent (SE) to the nearest 0.1 using the following formula:

$$SE = \frac{100(\text{Sand Reading})}{\text{Clay Reading}}$$

7.2. If the calculated sand equivalent is not a whole number, report it as the next higher whole number, as in the following example:

$$SE(\text{English}) = \frac{100(3.4)}{8} = 42.5, \text{ which is reported as } 43$$

$$SE(\text{Metric}) = \frac{100(85)}{200} = 42.5, \text{ which is reported as } 43$$

7.3. Average the whole number values determined as described above. If the average of these values is not a whole number, raise it to the next higher whole number.

8. REPORT

8.1. Record and report to the whole number.

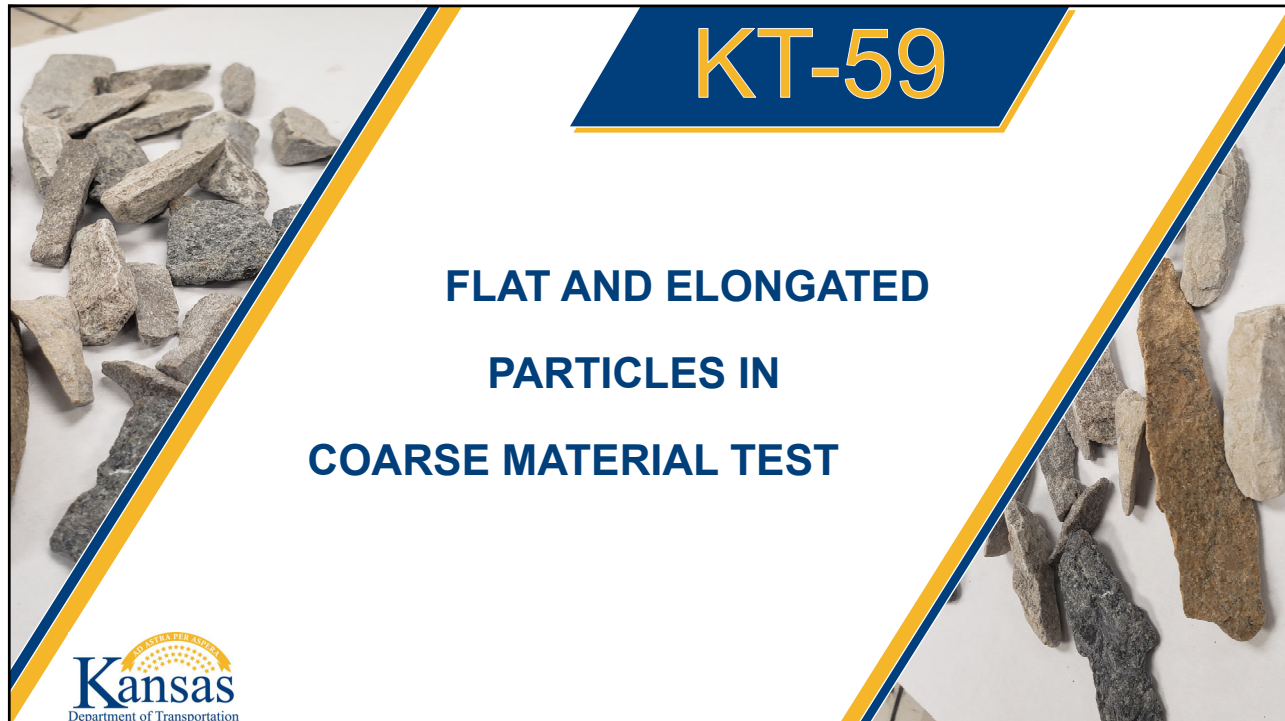

1

KT-59 Flat and Elongated Particles in Coarse Material Test

Scope 

- ❖ This method covers the determination of the percentage of flat and elongated coarse particles
- ❖ The shape of the coarse particles impacts the properties of some construction materials which drives the use of this method

2

KT-59 Flat and Elongated Particles in Coarse Material Test

Reference Documents

- *Part V, 5.9; Sampling and Test Methods Foreword*
- *KT-1; Sampling and Splitting of Aggregates*
- *KT-2; Sieve Analysis of Aggregates*
- *AASHTO M 92; Wire-Cloth Sieves for Testing Purposes*
- *ASTM D 4791; Standard Test Method for Flat Particles, Elongated Particles, or Flat and Elongated Particles in Coarse Aggregate*

3

KT-59 Flat and Elongated Particles in Coarse Material Test

Definition: **Flat and Elongated Particles**

- ❖ Aggregate having a ratio of length to thickness greater than a specified value
- ❖ After setting the caliper large ratio to the maximum length of the particle, attempt to slide the flattest portion of the particle horizontally through the opening of the small ratio
- ❖ If the particle passes clearly through the opening, then the particle is flat and elongated

4

KT-59 Flat and Elongated Particles in Coarse Material Test

Apparatus

- ❖ Balance meeting the requirements of Part V, 5.9, G5 classification
- ❖ Drying oven capable of maintaining a temperature of $230 \pm 9^\circ\text{F}$ ($110 \pm 5^\circ\text{C}$)
- ❖ Sieves meeting AASHTO M 92 guidelines
- ❖ **Proportional Caliper**



5

KT-59 Flat and Elongated Particles in Coarse Material Test

Sample Preparation

- ❖ Follow KT-1, Section 3 for sampling combined aggregates
- ❖ Obtain enough sample to yield the required mass of plus No. 4 material
- ❖ Sieve material over the No. 4, discarding all material that passes
- ❖ Oven dry the sample to constant mass (what is constant mass?) at a temperature of $230 \pm 9^\circ\text{F}$ ($110 \pm 5^\circ\text{C}$)
- ❖ Mix sample and reduce according to the table shown in section 6.2
- ❖ From the table; Nominal maximum aggregate size is one size larger than the first sieve to retain more than 10%

6

KT-59 Flat and Elongated Particles in Coarse Material Test

Test Procedure

- ❖ Sieve the sample to be tested following KT-2, Section 6
- ❖ Separate the sieves with their respective retained material and determine the mass of each sieve size fraction
- ❖ For each sieve size larger than the No. 4 with **10% or more** of the original mass retained on it needs to be reduced in accordance with KT-1 until approximately **100 particles** total are present

7

KT-59 Flat and Elongated Particles in Coarse Material Test

Test Procedure Cont..

- ❖ After reducing the retained material for each sieve, determine the mass of each **reduced size fraction**
- ❖ With the proportional caliper, set the ratio to 5:1 (or as required) and test each particle in each size fraction
- ❖ To use the caliper, set the larger opening to the length of the particle

8

KT-59 Flat and Elongated Particles in Coarse Material Test

Test Procedure Cont..

- ❖ Check if the flat portion fits through the smaller opening
- ❖ While checking each particle, create two piles where one is flat and elongated and the other is not flat and elongated particles
- ❖ Determine the mass of each pile/sieve size, weigh and record mass of each pile separately for each sieve

9

KT-59 Flat and Elongated Particles in Coarse Material Test

Nomenclature for Calculations

- a = % of original sample retained on sieve
- b = Mass of 100 +/- particles tested
- c = Mass of flat and elongated particles
- d = % flat and elongated [% F&E]
- e = Weighted % of total weighted F&E for a given sample
- f = % total weighted F&E: Sum of all individual weighted % F&E

10

KT-59 Flat and Elongated Particles in Coarse Material Test

Calculations

- ❖ Determine the percent of flat and elongated particles to the nearest 1% for each sieve size greater than No. 4

%F&E:

$$d = c * \frac{(100)}{b}$$

Where:

c = mass of flat and elongated particle

b = mass of 100 ± particles tested

d = %F&E

11

KT-59 Flat and Elongated Particles in Coarse Material Test

Calculations

- ❖ Determine the percent weighted of F&E on each sieve:

$$e = \frac{(a) * (d)}{100}$$

Where:

a = % of original sample retained on sieve

e = weighted % of total weighted F&E for a given sample

- ❖ Finally, determine the sum of weighted percentages

% total weighted F&E (*f*) = sum of all individual weighted percent F&E

12

KT-59 Flat and Elongated Particles in Coarse Material Test

Sieve	Individual	% Each	*Mass of	Failed Aggregate		
	Weight (g)	Fraction = a	Fraction (g) = a	Mass (g) = c	% Failed = d	Weighted % = e
1 1/2"						
1"						
3/4"						
1/2"						
3/8"						
#4						
Original Dry Mass of + #4					Total % F & E = f	

*individual mass quantities are after reduction to approximately 100 pieces

Note: If percent retained on sieve is less than 10% do not test for flat and elongated

Note: If percent retained on sieve is less than 10% use %F&E from the adjacent sieve or average of next larger and next smaller sieve

13

KT-59 Flat and Elongated Particles in Coarse Material Test

Reporting

Included in the report

- ❖ Grading of the aggregate sample, showing percentage retained on each sieve
- ❖ Percentages, calculated by mass for flat and elongated particles, for each sieve size tested, and the combined aggregate percent for flat and elongated particles
- ❖ When required, weighted average percentages based on the actual or assumed proportions of the various sieve sizes tested
- ❖ Report the grading used for the weighted average if different from the original grading listed above

14

KT-59 Flat and Elongated Particles in Coarse Material Test

Reporting

Included in the report

- ❖ Record the flat and elongated particles to the nearest 1%
 - ❖ Report the flat and elongated particles to the nearest 1%
- See ASTM D 4791 for information on the precision of this method
- No references related to the bias for this method are available, so no statement is provided

15

KT-59 Flat and Elongated Particles in Coarse Material Test

Example

Sieve	Individual Weight	% Each Size Fraction = a	*Mass of Reduced Fraction = b	Mass of Flat & E-Long = c	% Failed = d	Weighted % = e
1 1/2"	-	-	-	-	-	-
1"	-	-	-	-	-	-
3/4"	-	-	-	-	-	-
1/2"	1200	60	150	27	18	11
3/8"	740	37	75	8	11	4
#4	60	3	-	-	11	0
Original Dry Mass of + #4	2000				Total % F & E = f	15

16

5.9.59 FLAT AND ELONGATED PARTICLES IN COARSE MATERIAL TEST
(Kansas Test Method KT-59)

1. SCOPE

This test method covers the determination of the percentage of flat and elongated particles in coarse aggregates. **KT-59** reflects testing procedures found in **ASTM D4791**.

2. REFERENCED DOCUMENTS

2.1. Part V, 5.9; Sampling and Test Methods Foreword

2.2. KT-01; Sampling and Splitting of Aggregates

2.3. KT-02; Sieve Analysis of Aggregates

2.4. ASTM E11; Woven Wire Test Sieve Cloth and Test Sieves

2.5. ASTM D4791; Standard Test Method for Flat Particles, Elongated Particles, or Flat and Elongated Particles in Coarse Aggregate

3. DEFINITIONS

3.1. Flat and elongated particles of aggregate—those particles of aggregate having a ratio of length to thickness greater than a specified value.

3.2. A flat and elongated particle exists when the particle's small ratio (the 1 in 5:1) slides the full length through the opening established by the large ratio number (the 5 in 5:1). **EXAMPLE:** Checking flat and elongated particles requires comparing the length vs. thickness. After setting the large ratio to the maximum length of the particle, attempt to slide the flattest portion of the particle horizontally through the opening of the small ratio. If the particle passes clear through the opening, then the particle is flat and elongated.

4. SIGNIFICANCE AND USE

4.1. Flat and elongated particles of aggregates, for some construction uses, may interfere with consolidation and result in harsh, difficult to place materials.

4.2. This test method provides a means for checking compliance with specifications that limit such particles, or to determine the relative shape characteristics of coarse aggregates.

5. APPARATUS

5.1. Use apparatus suitable for testing aggregate particles for compliance with the definition in **Section 3.1** of this test method, at the dimensional ratios desired.

5.1.1. The proportional caliper device illustrated in **Figure 1** is an example of all apparatus suitable for this test method. It consists of a base plate with two fixed posts and a swinging arm mounted between them so that the openings between the arms and the posts maintain a constant ratio.

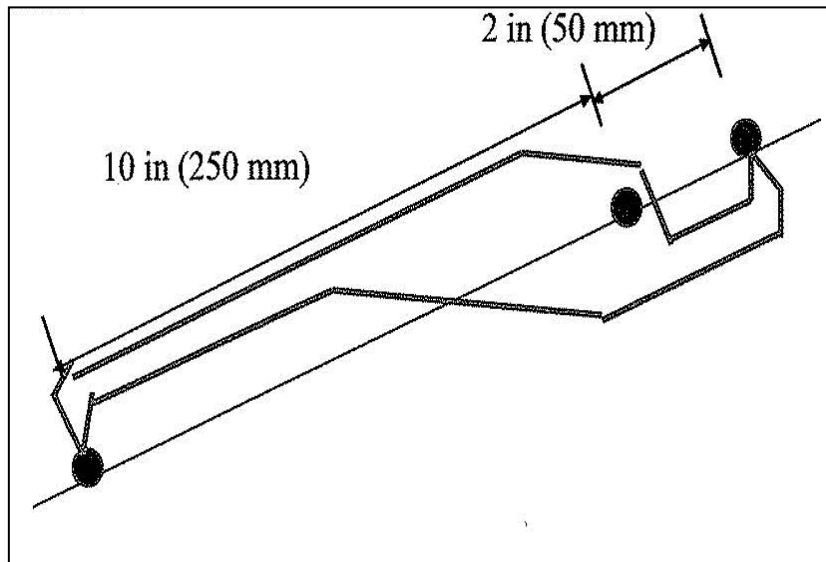

The caliper and pins are to be perpendicular to the base plate and raise at least 2 in (50 mm) in height. Design the caliper to touch the length of the fixed pins simultaneously. Provide a 5:1 ratio between the two fixed pins (or as required by contract documents). Design the center pin so the caliper can be easily locked into position. Make the base plate, caliper and pins of rigid and durable materials.

Figure 1 Proportional Caliper

Illustrates a device on which the ratio 5:1 is set.

5.1.2. Balance to meet the requirements of **Part V, 5.9; Sampling and Test Methods Foreword**, for the class of general purpose balance required for the principal sample mass of the sample being tested.

5.1.3. Drying oven capable of maintaining a uniform temperature of $230 \pm 9^\circ\text{F}$ ($110 \pm 5^\circ\text{C}$).

5.1.4. Sieves meeting **ASTM E11**.

6. SAMPLING

6.1. Sample the combined aggregate in accordance with **KT-01, Section 3**. Normally the sample is taken from the combined aggregate stream. The procedure may also be used to test individual coarse aggregate stockpiles to determine suitability for use. Obtain a large enough sample to yield the required plus 4 material listed in **Section 6.2 Table 1**.

6.1.1. Sieve the material over the No. 4 (4.75 mm) screen. Discard all material passing the No. 4 (4.75 mm) screen.

6.1.2. Oven dry the sample to constant mass at a temperature of $230 \pm 9^\circ\text{F}$ ($110 \pm 5^\circ\text{C}$).

6.2. Thoroughly mix the test sample and reduce it to an amount suitable for testing using the mass desired when dry as an end result of the reduction. Reduction to an exact predetermined mass is not permitted. Determine the original dry mass of the sample. The mass of the plus No. 4 material shall conform to the following:

Table 1

Nominal Maximum Aggregate Size, in. (mm)	Min. Dry Mass of +4 Sample, lb (kg)
1 1/2 in (37.5 mm)	33 lb (15 kg)
1 in (25.0 mm)	22 lb (10 kg)
3/4 in (19.0 mm)	11 lb (5 kg)
1/2 in (12.5 mm)	4 lb (2 kg)
3/8 in (9.5 mm)	2 lb (1 kg)
No. 4 (4.75 mm)	1 lb (0.5 kg)

NOTE: Nominal maximum aggregate size is one size larger than the first sieve to retain more than 10%.

7. PROCEDURE

7.1. Sieve the sample of coarse aggregate to be tested in accordance with **KT-02, Section 6**. Separately retain and determine the mass of each sieve size fraction. Reduce each size fraction larger than the No. 4 (4.75 mm) sieve present in the amount of 10% or more of the original sample in accordance with **KT-01, Section 4** until approximately 100 particles are obtained. Determine the mass of each reduced size fraction.

7.2. Using a proportional caliper device, set at a 5:1 ratio (or as required by the contract documents). Test each of the particles in each size fraction for flat and elongated.

7.2.1. Set the larger opening equal to the particle length. The particle is flat and elongated if the flattest portion of the particle can be placed through the smaller opening. Determine the proportion of the sample in each group by mass.

8. CALCULATIONS

8.1. Calculate the percent of flat and elongate particles to the nearest 1% for each sieve size greater than No. 4 (4.75 mm).

8.2. When a weighted average for a sample is required, assume that the sieve sizes not tested (those representing less than 10% of the sample) have the same percentage of flat and elongated particles as the next smaller or the next larger size, or use the average for the next smaller and larger sizes, if both are present.

8.3. Calculate the flat and elongated on each sieve:

$$\% \text{ F\&E} \quad D = \frac{C(100)}{B}$$

Where: C= mass of flat and elongated particles
B= mass of 100± particles tested
D= % F&E

Calculate the % weighted of F&E on each sieve:

$$E = \frac{(A)(D)}{100}$$

Where: A = % of original sample retained on sieve
D = % F&E
E = weighted % Calculate to the % total weighted F&E for a given sample:

Sieve	Individual Sieve Mass (grams)	% Sieve Size Fraction = A	*Mass of Reduced "100 Piece Pile" (grams) = B	Failed Aggregate		
				Failed Mass Fraction (grams) = C	% Failed = D	Weighted % = E
1 1/2"	--	--	--	--	--	--
1"	--	--	--	--	--	--
3/4"	--	--	--	--	--	--
1/2"	1200	60	150	27	18	11
3/8"	740	37	75	8	11	4
#4	60	3	--	--	11	0
Original Dry Mass of + #4	2000			Total % Failed F & E = F		15

Total % Failed F&E (F) = sum of all individual weighted percent F&E

*individual mass quantities are after reduction to approximately 100 pieces (**Section 7.2**, of this test method)

NOTE #1: If percent retained on sieve is less than 10% do not test for flat and elongated.

NOTE #2: If percent retained on sieve is less than 10% use %F&E from adjacent sieve or average of next larger and next smaller sieve.

9. REPORT

9.1. Include the following information in the report:

9.1.2. Grading of the aggregate sample, showing percentage retained on each sieve.

9.1.3. Percentages, calculated by mass for flat and elongated particles, for each sieve size tested, and the combined aggregate percent for flat and elongated particles.

9.1.4. When required, weighted average percentages based on the actual or assumed proportions of the various sieve sizes tested. Report the grading used for the weighted average if different from that in **Section 9.1.2** of this test method.

9.1.5. Record the flat and elongated particles to the nearest 1%. Report the flat and elongated particles to the nearest 1%.

10. PRECISION AND BIAS

10.1. Precision-The precision of this test method is found in **ASTM D4791**.

10.2. Bias-Since there is no accepted reference material suitable for determining the bias for this test method no statement on bias is being made.

5.9. SAMPLING AND TEST METHODS FOREWORD

1. SAFETY

The responsibility for safety rests with each and every employee in the laboratory or field. You must use common sense and work carefully to avoid the hazards your job may expose you to like hazardous chemicals, flying particles and heavy or awkward lifting are a few of the hazards you will be exposed to.

You are responsible to know the hazards that each test may expose you to so that you can work with the right level of protection while completing certain test procedures. Through OSHA 1910 and 1926 and KDOT SOM 2.6.2 your employer is required to tell you what hazards you will be exposed to and how to protect yourself from those hazards.

OSHA 1910 and 1926 also makes it the employee's responsibility to understand and follow the safety programs provided by their employers to protect them. SOM 2.6.2 refers to the KDOT safety Manual which requires employees to follow the guidelines of KDOT Hazardous Communications Program and the KDOT Personal Protection Program. These two programs will assist you with how to read an MSDS and provide information on the type of personal protection required to protect you from the physical, chemical, biological and ergonomic hazards you will be exposed to while performing the tests in this manual.

2. SCOPE

The purpose of this section is to standardize the testing procedures used throughout the State by all laboratories. A hierarchy for test methods exists in order to establish a specific test procedure for a given circumstance.

Test method hierarchy corresponds to the following publications unless otherwise stated in the Standard Specifications, plans or project specifications:

- First - Kansas Department of Transportation Construction Manual, Part V.
- Second - Standards published by the American Association of State Highway and Transportation Officials (AASHTO).
- Third - Standards published by the American Society for Testing and Materials (ASTM).

Each test method is an independent document, page numbered and printed individually. The primary number linking it to this manual is the sub-paragraph number. Any future corrections, additions or revisions will be printed and forwarded to the manual holders at the time they occur, to reflect current testing procedures.

Footnotes at the bottom of the page of a test procedure are a quick check for contractors or consultants to determine differences between KT methods and AASHTO/ASTM standards. **ALL PROCEDURES ARE TO BE PERFORMED AS STATED WITHIN KT METHODS, EXCLUDING THE INFORMATION FOUND IN THE KT FOOTNOTES.**

Unless noted in the test method, the use of potable water is required.

Unless otherwise stated in the test method, drying to a constant mass means less than 0.1% mass decrease from the previous measurement after 1 hour following the temperature requirements in the test method.

Consult the Bureau of Construction and Materials and in case of ambiguity or difficulty in the interpretation of testing procedures.

3. ACCURACY

As a general guideline use the following for an accuracy requirement when not stated within the test procedure:

Thermometers: Temp \leq 140°F (60°C), accuracy of 0.2°F (0.1°C); Temp $>$ 140°F (60°C), accuracy of 2°F (1°C).

Balances/Scales: Accuracy is equal to the mass stated or 0.1 percent of the test load, whichever is greater, throughout the range of use. The following table shows the various classes as established in AASHTO M 231:

Class	Readability and Sensitivity	Accuracy*
G1	0.01 g	0.02 g or 0.1 percent
G2	0.1 g	0.2 g or 0.1 percent
G5	1 g	2 g or 0.1 percent
G20	5 g	5 g or 0.1 percent
G100	20 g	20 g or 0.1 percent

* Accuracy equal to the mass stated or 0.1 percent of the test load, whichever is greater, throughout the range of use.

4. SI UNITS

The following information provides the user of these test procedures with specific comparisons between metric (SI) and English units and nomenclature.

Where possible, "Hard Conversion" practices are used converting the testing procedures from English to SI units. This system establishes an approximate measurement in SI units compared to the English units. An example of this is to convert one inch to SI units. One inch is equal to 25.4 millimeters (1 in = 25.4 mm). Using Hard Conversion, 25 mm is the new measurement, and compared to the 25.4 mm, is easier to verify. However, where test methods requires rigidly specified equipment or procedures measured in English units, a soft conversion will be shown. These cases should be obvious due to the outrageous metric number presented.

The nomenclature used to represent SI units are as follows (conversions originated or derived from ASTM E 380):

$$\underline{\text{SI (full name)}} = \underline{\text{ENGLISH (full name)}} \times \underline{\text{Conversion}}$$

AREA

mm ² (millimeter ²)	in ² (inches ²)	645.16
m ² (meters ²)	ft ² (feet ²)	0.092903
m ²	yd ² (yard ²)	0.8361274

DENSITY (MASS PER UNIT VOLUME)

<u>kg</u> <u>kilogram</u>	<u>lb</u> or <u>pound</u>	16.01846
---------------------------	---------------------------	----------

m³ meter³ ft³ feet³
 (also known as PCF)

FORCE

N (Newton) lbf (pound-force) 4.448222

LENGTH

mm (millimeters) in (inches) 25.4

m (meters) ft (feet) 0.3048

km (kilometer) (mile) 1.609347

SI (full name) = ENGLISH (full name) X Conversion

MASS

g (gram) lb (pound) 453.5924

kg (kilogram) lb (pound) 0.4535924

Mg (megagram) TONS 0.9071847

PRESSURE (FORCE PER UNIT AREA)

kPa (kilopascal) psi or $\frac{\text{pound-force}}{\text{inches}^2}$ 6.894757

TEMPERATURE

°C (Celsius) °F (Fahrenheit) $t_C = (t_F - 32)/1.8$

VOLUME

mm³ (millimeters³) in³ (inches³) 16,387.06

m³ (meters³) ft³ (feet³) 0.02831685

m³ yd³ (yards³) 0.7645549

mL (milliliter) in³ 16.38706

L (Liter) qt (quart) 0.9463529

L gal (gallon) 3.785412

L ft³ 28.31685

NOTE: $1 \text{ m}^3 = 1,000 \text{ L}$
 $1 \text{ L} = 1,000 \text{ mL}$

5.9.15 BULK SPECIFIC GRAVITY AND UNIT WEIGHT OF COMPACTED HOT MIX ASPHALT (HMA) (Kansas Test Method KT-15)

1. SCOPE

This method of test covers the procedure for determining the bulk specific gravity of specimens of compacted asphalt mixtures. The specimens may have been molded in the laboratory or cut or cored from compacted pavements. **KT-15** reflects testing procedures found in **AASHTO T 166** and **AASHTO T 331**.

2. REFERENCED DOCUMENTS

2.1. Part V, 5.9.; Sampling and Test Methods Foreword

2.2. AASHTO T 166; Bulk Specific Gravity of Compacted Hot Mix Asphalt (HMA) Using Saturated Surface – Dry Specimens

2.3. AASHTO T 331; Bulk Specific Gravity and Density of Compacted Hot Mix Asphalt (HMA) Using Automatic Vacuum Sealing Method

3. APPARATUS

3.1. The balance shall conform to the requirements of **Part V, 5.9; Sampling and Test Methods Foreword**, for the class of general purpose balance required for the principal sample mass of the sample being tested.

3.2. Wire basket formed of No. 4 (4.75 mm) mesh hardware cloth, 1/4 in (6.3 mm) mesh or perforated shelf or suitable bucket. The size shall be sufficient to fully support the specimen.

3.3. Container with overflow device, for immersing the wire basket, shelf or bucket in water and maintaining a constant water level.

3.4. Measuring device to establish the physical dimensions of a specimen.

3.5. Vacuum chamber with a 1.25 h (0.93kW) pump capable of evacuating a sealed and enclosed chamber to 29.5 in Hg vacuum (100 kPa vacuum) in less than 60 seconds. The chamber shall be large enough to seal samples of 6 in (150 mm) wide by 14 in (350 mm) long by 6 in (150 mm) thick. The device shall automatically seal the plastic bag and exhaust air back into the chamber in a controlled manner to ensure proper conformance of the plastic to the asphalt specimen.

3.6. Plastic bags used with the vacuum device shall be one of the two following sizes. The smaller bags shall have a minimum opening of 9.25 in (235 mm) and a maximum opening 10.25 in (260 mm). The larger bags shall have a minimum opening of 14.75 in (275 mm) and a maximum opening of 15.5 in (294 mm).

3.7. Specimen sliding plate used within the vacuum chamber for reduction of friction on the plastic bags.

4. PROCEDURE

4.1. The bulk specific gravity of a compacted asphalt mix specimen is determined by computing the ratio of its mass in air to its bulk volume. Procedure I is a rapid method which generally provides sufficient accuracy for the routine testing of specimens with dense, impermeable surfaces. Procedure II corresponds to **AASHTO T 331** test method for Bulk Specific Gravity and Density of Compacted Hot Mix Asphalt (HMA) Using Automatic Vacuum Sealing Method. Procedure III is a laboratory method which is used to determine the bulk specific gravity of saturated specimens, and corresponds to **AASHTO T 166, Method A**. This method is most suitable for testing specimens with slightly permeable surfaces in order to obtain the water absorption. Procedure IV is a method which establishes the bulk specific gravity of specimens which are composed of “open” mixes that typically display high porosity and permeability. In the event of dispute, Procedure IV will take precedence over Procedures I & II. Marshall and Superpave design specimens molded at the estimated “optimum” asphalt content will be subjected to Procedure III to determine the water absorption (by volume). If the water absorption is equal to or greater than 2.0%, Procedure II shall be used for both design and routine or field purposes.

4.1.1. Constant mass shall be defined as the mass at which further drying does not alter the mass by more than 0.05%. Initially dry the specimen overnight by either placing in an oven at $125 \pm 5^\circ \text{F}$ ($52 \pm 3^\circ \text{C}$) or by placing in front of a fan on an elevated wire rack and then weigh the next day at one-hour¹ intervals.

4.1.2. Specimens are defined to be at room temperature when meeting the following procedure: Check surface temperature. Let the specimen set for 5 minutes while at ambient air conditions (no flow of any type should be flowing across the specimen). Recheck the surface temperature. The original check and recheck must fall within $77 \pm 5^\circ \text{F}$ ($25 \pm 3^\circ \text{C}$) or the specimen temperature has not stabilized to room temperature.

4.2. Procedure I

4.2.1. Weigh specimen at room temperature to the nearest 0.1 g after it has attained room temperature.

4.2.2. Place the specimen in the basket or bucket and determine its mass to the nearest 0.1 g while immersed in water with a temperature of $77 \pm 2^\circ \text{F}$ ($25 \pm 1^\circ \text{C}$). The mass of the specimen in water shall be determined as quickly as possible after the specimen is immersed. This method should not be used if the specimen contains open or interconnecting voids.

4.3. Procedure II

4.3.1. Dry the specimen to constant mass and weigh it to the nearest 0.1g.

4.3.2. Cool the specimen to room temperature.

4.3.3. Select an appropriate size bag. For all 4 in (100 mm) diameter samples and samples with 6 in (150 mm) diameter and less than 2 in (50 mm) thickness, it is possible to use the bag with the smaller opening size.

4.3.4. Place a bag inside the vacuum chamber on top of the sliding plate.

4.3.5. Gently open the bag and place the specimen in the plastic bag on top of the sliding plate, while being careful not to handle the bag in such a manner that would create a puncture.

¹ **AASHTO T 166** and **T 331** require a two-hour interval.

4.3.6. Allow the vacuum chamber to remove the air from the chamber and the plastic bag. The vacuum chamber shall automatically seal the bag once the air is removed.

4.3.7. Exhaust air into the chamber until the chamber door opens indicating atmospheric pressure within the chamber. The chamber door latch can be used to avoid automatic opening of the door after completion of the test.

4.3.8. Remove the sealed specimen from the vacuum chamber. Handle the sealed specimen with extreme care.

4.3.9. Weigh the sealed specimen in air to the nearest 0.1g.

4.3.10. Weigh the sealed specimen while immersed in water at $77 \pm 2^\circ\text{F}$ ($25 \pm 1^\circ\text{C}$) to the nearest 0.1 g. Verify that no air bubbles are entrapped underneath the plastic bag material. This can be accomplished by placing the sealed specimen in water with the plastic bag oriented in a vertical direction.

4.3.11. Reweigh the sealed specimen in air to the nearest 0.1 g.

4.4. Procedure III

4.4.1. For cores, dry the specimen to constant mass. Cool the specimen to room temperature and weigh the dry mass to the nearest 0.1 g, and record as A. Immerse the specimen in a $77 \pm 2^\circ\text{F}$ ($25 \pm 1^\circ\text{C}$) water bath, let saturate for 4 ± 1 minutes, then weigh and record mass as C. Remove the immersed and saturated specimen from the water bath, quickly damp dry the saturated specimen with a damp absorbent cloth and as quickly as possible, weigh and record the specimen as B. Any water which seeps from the specimen during the weighing operation is considered as part of the saturated specimen.

NOTE: If desired, the sequence of testing operations can be changed to expedite the test results. For example, first the mass of saturated damp dry specimen can be taken. Then the saturated specimen in water can be weighed. The dry mass of the specimen can be determined last.

NOTE: Terry cloth has been found to work well for an absorbent cloth. Damp is considered to be when no water can be wrung from the towel.

4.5. Procedure IV

4.5.1. Dry the specimen to constant mass.

4.5.2. After the specimen has cooled to room temperature, weigh it to the nearest 0.1 g (see **Section 4.4.1.1** of this test method).

4.5.3. Measure the height of the specimen to the nearest 0.001 in (0.025 mm) at four approximately equally spaced locations and average the four measurements. The diameter of the test specimen shall be determined to the nearest 0.001 in (0.025 mm) by averaging three diameters measured at $120 \pm$ degree angles to each other at about midheight of the specimen. The average diameter shall be used in calculations.

5. CALCULATIONS

A = Mass of dry specimen in air, g.

B = Mass of saturated specimen in air after 4 minutes in water, g.

C = Mass of saturated specimen in water, g.

D = Mass of sealed specimen in air, g.

E = Mass of sealed specimen in water, g.

F = Apparent specific gravity of plastic sealing material at $77 \pm 2^\circ\text{F}$ ($25 \pm 1^\circ\text{C}$).

V = Calculated volume of specimen at $77 \pm 2^\circ\text{F}$ ($25 \pm 1^\circ\text{C}$).

G = Mass of specimen weighed immediately in water, g.

d = Specimen diameter (in [mm]).

h = Specimen height (in [mm]).

5.1. Procedure I: Bulk Specific Gravity (G_{mb})

$$G_{mb} = \frac{A}{(A-G)}$$

5.2. Procedure II: Bulk Specific Gravity of Plastic Sealed Specimens

$$G_{mb} = \frac{A}{(D - E) - \left(\frac{D-A}{F}\right)}$$

5.3. Procedure III: Bulk Specific Gravity and Absorption of Saturated Samples

$$G_{mb} = \frac{A}{(B-C)}$$

Calculate the percent of water absorbed by the specimen as follows:

$$\% \text{ Water Absorbed (Volume Basis)} = \frac{100 \times (B - A)}{(B - C)}$$

5.4. Procedure IV: Bulk Specific Gravity by Physical Dimensions

$$\text{Vol (in}^3\text{)} = (0.7854) (d^2) (h) \text{ (English)}$$

$$\text{Vol (mm}^3\text{)} = (0.7854) (d^2) (h) \text{ (SI)}$$

$$\text{Unit wt. (lb/ft}^3\text{)} = \frac{3.8096 (\text{mass in grams})}{\text{Volume in in}^3} \text{ (English)}$$

$$\text{Unit wt. (kg/m}^3\text{)} = \frac{1,000,000 (\text{mass in grams})}{\text{Volume in mm}^3} \text{ (SI)}$$

$$G_{mb} = \frac{\text{Unit weight in lb/ft}^3}{62.243^d} \text{ (English)}$$

$$G_{mb} = \frac{\text{Unit weight in kg/m}^3}{997.04^d} \text{ (SI)}$$

NOTE: Density of water varies based on temperature. Since the water bath temperature is fixed at $77 \pm 2^\circ\text{F}$ ($25 \pm 1^\circ\text{C}$), use the specified values. For tests not restrained by the $77 \pm 2^\circ\text{F}$ ($25 \pm 1^\circ\text{C}$) requirement, temperature correction can be determined by selecting the proper density for water from **Table 1**.

Table 1
Density of Water

°C	Temperature		Density	
	°F	kg/m ³	lb/ft ³	
15	59.0	999.09	62.371	
16	60.8	998.94	62.362	
17	62.6	998.77	62.351	
18	64.4	998.60	62.341	
19	66.2	998.40	62.328	
20	68.0	998.20	62.316	
21	69.8	997.99	62.302	
22	71.6	997.77	62.289	
23	73.4	997.54	62.274	
24	75.2	997.30	62.259	
25	77.0	997.04	62.243	
26	78.8	996.78	62.227	
27	80.6	996.50	62.209	
28	82.4	996.23	62.193	
29	84.2	995.94	62.175	
30	86.0	995.65	62.156	
31	87.8	995.34	62.137	
32	89.6	995.03	62.118	
33	91.4	994.70	62.097	
34	93.2	994.37	62.077	
35	95.0	994.03	62.055	

NOTE: The table was derived from the table 10-28 of Lange's Handbook of Chemistry; Twelfth Edition; Copyright 1979.

5.5. SG_{corr.}

$$SG_{corr.} = \left(\frac{d_w}{997.04} \right)$$

Where: d_w = density of water at temperature other than $77 \pm 2^\circ\text{F}$ ($25 \pm 1^\circ\text{C}$).

6. PRECISION

6.1. Duplicate determinations by multi laboratory, multi operator shall check to within 0.031. This value is derived from the 2006 Independent Assurance Gyratory Comparisons.

5.9.20 MASS PER CUBIC FOOT (METER), YIELD, AND AIR CONTENT (GRAVIMETRIC) OF FRESHLY MIXED CONCRETE (Kansas Test Method KT-20)

1. SCOPE

This method of test covers the procedure for determining the mass per cubic foot (meter) of freshly mixed concrete and gives formulas for calculating the following values: Yield, Relative Yield, Actual Cement Factor and Air Content. **KT-20** reflects testing procedures found in **AASHTO T 121**.

2. REFERENCED DOCUMENTS

2.1. Part V, 5.9; Sampling and Test Methods Foreword

2.2. KT-05 Unit Weight of Aggregate

2.3. KT-17; Sampling Freshly Mixed Concrete

2.4. KT-18; Air Content of Freshly Mixed Concrete By the Pressure Meter

2.5. KT-19; Air Content of Freshly Mixed Concrete by the Volumetric Method

2.6 AASHTO T 121; Weight per Cubic Foot, Yield, and Air Content (Gravimetric) of Concrete

3. APPARATUS

3.1. The balance shall conform to the requirements of **Part V, 5.9; Sampling and Test Methods Foreword**, for the class of general purpose balance required for the principal sample mass of the sample being tested.

3.2. Tamping rod shall be a straight steel rod, 5/8 in (16 mm) in diameter and approximately 24 in (600 mm) in length with both ends rounded to a hemispherical tip of the same diameter.

3.3. A cylindrical container made of steel or other suitable material. It shall be watertight and sufficiently rigid to retain its form and calibrated volume under rough usage. Measures that are machined to accurate dimensions on the inside and provided with handles are preferred. The minimum capacity of the measure shall conform to the requirements in **Table 1**. All measures, except for measuring bowls of air meters which are also used for **KT-20** of this manual, shall conform to the requirements of **KT-05** of this manual. When measuring bowls of air meters are used, they shall conform to the requirements of **KT-18** of this manual. The top rim of the air meter bowls shall be smooth and plane within 0.01 in (0.25 mm).

NOTE: The metal or other suitable material should not be readily subject to attack by cement paste. However, reactive materials such as aluminum alloys may be used in instances where as a consequence of an initial reaction, a surface film is rapidly formed which protects the metal against further corrosion.

NOTE: The top rim is satisfactorily planed if a 0.01 in (0.25 mm) feeler gauge cannot be inserted between the rim and a piece of 1/4 in (6 mm) or thicker glass plate laid over the top of the measure.

Table 1
Minimum Capacity of Measures

Maximum Nominal Size of Coarse Aggregate		Capacity of Measure, min	
in	Mm	ft ³	m ³
1	25.0	0.2	0.006
1 1/2	37.5	0.4	0.011
2	50	0.5	0.014
3	75	1.0	0.028
4 1/2	114	2.5	0.071
6	152	3.5	0.099

NOTE: For maximum nominal aggregate sizes 1 in (25 mm) or less, the pressure meter bowl may be used.

NOTE: Aggregate of a given maximum nominal size may contain up to 10% of particles retained on the sieve referred to.

NOTE: To provide for wear, measures may be up to 5% smaller than indicated in this table.

3.4. ¹A rigid, flat glass or heavy plastic cover plate at least 1/2 (13 mm) thick and at least 2 in (50 mm) larger than the diameter of the measure for accurately striking off and leveling the surface of the concrete. The edges of the plate shall be straight and smooth with a tolerance of 1/16 in (1.6 mm).

3.5. Hand scoop.

3.6. Trowel.

3.7. Mallet with rubber or rawhide head having a mass approximately 1.25 ± 0.50 lb (600 ± 200 g) for use with measures of 0.5 ft³ (0.014 m³) or smaller. Mallet having a mass of 2.25 ± 0.50 lb (1000 ± 200 g) for use with measures larger than 0.5 ft³ (0.014 m³).

3.8. Internal vibrators may have rigid or flexible shafts, preferably powered by an electric motor. The diameter of the vibrating element shall be not less than 0.075 in (19 mm) or more than 1.50 in (38 mm) and the length of the shaft should be 24 in (600 mm) or more. The frequency of vibration shall be 7000 vibrations per minute (117 Hz) or greater. A tachometer should be used to check the frequency of vibration.

4. CALIBRATION OF MEASURE, AND CALIBRATION FACTOR

4.1. Determine the mass of the empty measure to the nearest 0.05 lb (20 g) and record this mass as A. Determine the mass of the empty measure (coated with grease on the top rim if necessary) and cover plate to the nearest 0.05 lb (20 g) and record this mass as C.

4.2. Fill the measure with water, using the cover plate to ensure that it is exactly full. Wipe excess water from sides and bottom of the measure with an absorbent cloth.

¹ AASHTO T 121 allows the use of a metal plate.

4.3. Weigh and record the mass of the measure, water, and cover plate. Record this mass as B.

4.4. Measure and record the temperature of the water and determine the density as found in **KT-15**, interpolating if needed.

4.5. Calculations:

$$V = \frac{B - C}{D}$$

Where: V = Volume of the measure, ft³ (m³)
B = Mass of the measure filled with water plus cover plate, lb (kg)
C = Mass of the measure and cover plate, lb (kg)
D = Density of water (see **KT-15**), lb/ft³ (kg/m³)

$$F = \frac{D}{B - C} = \frac{1}{V}$$

Where: F = Calibration factor, 1/ft³ (1/m³)

5. TEST PROCEDURE

5.1. Obtain a sample of freshly mixed concrete in accordance with **KT-17** of this manual.

5.2. Weigh the measure and record the mass as A.

5.3. Concrete at different slump levels requires different methods of consolidation to prepare satisfactory test specimens. The methods listed below should be used as a guide in determining the type of consolidation to use:

Slump of Concrete	Type of Consolidation
More than 3 in (75 mm)	Rodding
1 to 3 in (25 to 75 mm)	Rodding or Vibration
Less than 1 in (25 mm)	Vibration

5.4. Rodding procedure.

5.4.1 Place concrete in the measure in three equal layers.

5.4.2. Rod each layer 25 times when 0.5 ft³ (0.014 m³) or smaller measures are used and 50 times when the 1 ft³ (0.28 m³). When rodding the first layer, avoid striking the bottom of the container and when rodding successive layers, use only enough force to penetrate the surface of the underlying layer about 1 in (25 mm).

5.4.3. After each layer is rodded, tap the sides of the measure smartly 10 to 15 times with the mallet to close any voids left by the tamping rod and to release any large bubbles of air that may have been trapped.

5.4.4. After consolidation, strike-off the top surface of the concrete and finish it smoothly with the flat strike-off plate using great care to leave the measure just full. The strike-off is best accomplished by pressing the strike-off plate on the top surface of the measure to cover about 2/3 of the surface and

withdrawing the plate with a sawing motion to finish only the area originally covered. Then place the plate on the top of the measure to cover the original 2/3 of the surface and advance it with a vertical pressure and a sawing motion to cover the whole surface of the measure. Several final strokes with the inclined edge of the plate will produce a smooth finished surface.

5.4.5. Clean all excess concrete from the exterior of the filled measure. Weigh the filled measure to the nearest 0.1 lb (50 g) and record the mass as D.

5.5. Vibration Procedure.

5.5.1. Fill the measure approximately 1/2 full of concrete. Place all the concrete required for the layer in the measure before starting vibration.

5.5.2. Consolidate the layer by three insertions of the vibrator evenly distributed over the surface. Do not let the vibrator rest or touch the bottom or sides of the measure. The duration of vibration will depend on the effectiveness of the vibrator and the consistency of the concrete, but usually sufficient vibration has been applied when the surface of the concrete becomes relatively smooth in appearance.

5.5.3. Fill the measure to an elevation somewhat above the top rim and vibrate this second layer. In compacting the final layer, the vibrator shall penetrate into the underlying layer approximately 1 in (25 mm). Take care that the vibrator is withdrawn in such a manner that no air pockets are left in the specimen. A small quantity of concrete may be added to correct a deficiency. If the measure contains a great excess of concrete at completion of consolidation, remove most of the excess concrete with a trowel or scoop immediately before the measure is struck-off.

5.5.4. Strike-off the surface as in **Section 5.4.4** of this test method.

5.5.5. Proceed as in **Section 5.4.5** of this test method.

6. CALCULATIONS

6.1. Mass per cubic foot (meter) of fresh concrete.

$$W = F (D - A)$$

Where:

- W = Mass of concrete lb/ft³ (kg/m³)
- D = Mass of measure filled with concrete, lb (kg)
- A = Mass of measure, lb (kg)
- F = Calibration factor

6.2. Volume of Concrete produce per batch.

$$S = \frac{W_c + W_{fa} + W_{ca} + W_w + W_o}{W}$$

Where: S = Volume of concrete produced per batch, ft³ (m³)
W_c = Total mass of cement in batch, lb (kg)
W_{fa} = Total wet mass of fine aggregate in batch, lb (kg)
W_{ca} = Total mass of coarse aggregate in batch lb (kg)
W_w = Total mass of mixing water added to batch, lb (kg)
W_o = Total mass of any other solid or liquid material used, lb (kg)

6.3. Relative yield is the ration of actual volume of concrete obtained to the volume as designed for the batch and shall be calculated as follows:

(English)

$$RY = \frac{S}{27(V_d)}$$

(SI)

$$RY = \frac{S}{V_d}$$

Where; RY = Relative density
V_d = Volume of concrete which the batch was designed to produce, yd³ (m³)
S = Volume of concrete produced per batch, ft³ (m³)

NOTE: A value for RY greater than 1.00 indicates that an excess volume of concrete is being produced, whereas, a value less than 1.00 indicates the batch to be “short” of its designed volume.

6.4. Air Content: calculate as follows:

$$A = \frac{100(T - W)}{T}$$

Where: A = Air content in the concrete
T = Theoretical mass of the concrete, lb/ft³ (kg/m³), air free basis
W = Mass of concrete lb/ft³ (kg/m³)

NOTE: When the same materials and proportions are used to prepare different batches of concrete, it is assumed that the theoretical, air free, mass per cubic foot (meter) of the concrete is constant for all batches. It is calculated from the formula:

$$T = \frac{W_1}{V}$$

Where: W₁ = W_c + W_{fa} + W_{ca} + W_w + W_o
V = Total absolute volume of the component ingredients in the batch, ft³ (m³)

The absolute volume of each ingredient is calculated in accordance with **subsection 5.10.1** of this manual. For aggregate components, the bulk specific gravity and mass should be based on the saturated, surface-dry condition.

6.5. Actual Cement Factor: Cement factor based on theoretical yd³ (m³) of concrete required and actual quantity of cement used is calculated as follows:

$$ACF = \frac{A}{B}$$

Where: A = Actual cement used lb (kg)
 B = Theoretical volume of concrete, yd³ (m³)

**KANSAS DEPARTMENT OF TRANSPORTATION
SPECIAL PROVISION TO THE
STANDARD SPECIFICATIONS, EDITION 2015**

Delete SECTION 602, and replace with the following:

SECTION 602

**HOT MIX ASPHALT (HMA) CONSTRUCTION
(Quality Control/Quality Assurance (QC/QA))**

602.1 DESCRIPTION

Mix and place 1 or more courses of plant produced HMA mixture on a prepared surface as shown in the Contract Documents. Demonstrate quality control by providing the quality control testing.

BID ITEMS

HMA Base (*)(**)(***)
HMA Surface (*)(**)(***)
HMA Overlay (*)(**)(***)
HMA Pavement (#) (##)
HMA Pavement (#) Shoulder
Emulsified Asphalt (****)
Asphalt Core (Set Price)
Material for HMA Patching (Set Price)
Quality Control Testing (HMA)
*Mix Designation
**Grade of Asphalt Binder
***Shoulder
****Type and Grade of Emulsified Asphalt
Thickness
##Type of surface course HMA mixture

UNITS

Ton
Ton
Ton
Square Yard
Square Yard
Ton
Each
Ton
Ton

602.2 CONTRACTOR QUALITY CONTROL REQUIREMENTS

a. General. Provide qualified personnel and sufficient equipment complying with the requirements listed in Part V to conduct quality control testing that complies with Appendix B, Sampling and Testing Frequency Chart for Asphalt Construction Items for Quality Control/Quality Assurance Projects.

Allow the Engineer access to the Contractor's laboratory to observe testing procedures, calculations, test documentation and plotting of test results.

Calibrate and correlate the testing equipment with prescribed procedures, and conduct tests in compliance with specified testing procedures as listed in Part V.

Maintain a Quality Manual in the field laboratory showing the calibrations performed on all test equipment and when the next calibration is due for that equipment. As a minimum, follow the calibration/verification interval established in Table 2: HMA Materials Test Equipment in Section 5.2.7.1-HMA: Contractor's Quality Control Plan, Part V. See also, Section 5.2.7.3-Example of a Laboratory Quality Manual for HMA, Part V.

Store and retain the most recent 2 lots per mix designation of quality control samples for KDOT. KDOT will retain the most recent 2 lots per mix designation gyratory compacted air voids (Va) verification samples and the remaining material not previously used for testing (back half of sample). Do not retain more than the previous 3 lots per mix designation of quality control or verification samples. When the hot mix plant shuts down for the winter, discard the samples after 7 days.

b. Quality Control Plan (QCP). At the pre-construction conference, submit to the Engineer for approval, a QCP as outlined in Section 5.2.7-Contractor's Quality Control Plan, Part V. Follow 5.2.7.1-HMA: Contractor's Quality Control Plan in Part V as a general guideline. The Contractor's laboratory and equipment will be inspected and approved as outlined in Section 5.2.7-Contractor's Quality Control Plan, Part V.

Include a listing of the names and phone numbers of individuals and alternates responsible for quality control administration and inspection. On the Contractor's organizational chart, show the specified lines of authority relating both to mix design and quality control operations during production. Post the organizational chart in the Contractor's test facility.

Provide a quality control organization or private testing firm having personnel certified according to the Policy and Procedures Manual for The Certified Inspection and Testing (CIT) Training Program. The testing for this type of construction will require personnel certified in Aggregate Field Tester (AGF), Aggregate Lab Technician (AGL), Superpave Field (SF), Profilograph (PO) and Nuclear Moisture Density Gauge Tester (NUC) classifications. Provide a minimum of 1 employee on the project certified in the QC/QA Asphalt Specs (QCA) classification.

Only persons certified in the appropriate classifications covering the specific tests required shall perform such testing. At the beginning of the project, provide the Engineer with the list of certified technicians and alternates, phone numbers and tests/inspection they will be performing. Include certification expiration dates for all certified technicians. As personnel changes and certifications may expire, continue to provide the Engineer with an accurate list.

Provide an organizational chart showing the specified lines of authority relating to both mix design and quality control operations during production. Identify the company official acting as liaison with KDOT, and the Certified Technician who will direct inspection and testing. Post the chart in the test facility.

c. Required Duties of Certified Inspectors. Be available on the project site whenever HMA is being produced and being placed on the project site. Perform and utilize quality control tests and other quality control practices to assure that delivered materials and proportioning meet the requirements of the mix designs.

Periodically inspect all equipment utilized in transporting, proportioning, mixing, placing and compacting to assure it is operating properly and that placement and compaction comply with the contract requirements.

d. Contractor's Testing Facilities. Describe the testing facility and its accreditation in the QCP.

Locate the testing facility either at the plant site or at the project. Obtain approval of the testing facilities and location from the DME before the commencement of mixture production.

Provide suitable space for the required testing equipment. Also, equip the testing facility with these items for the exclusive use of the testing facility's quality control personnel and the Engineer:

A telephone with a private line for the exclusive use of the testing facility's quality control personnel; and

A copying machine for use by the Contractor's personnel and the Engineer.

Broadband internet connection (for 1 computer). If the Engineer determines that broadband internet service is not available, provide a fax machine, at no additional cost.

An air conditioner capable of maintaining a temperature below 77°F in the main part of the Field Office and Laboratory.

Locate the KDOT field laboratory near the Contractor's testing facility and have it fully functional 2 working days before placement of the pre-production mix.

e. Documentation. Include in the QCP procedures, charts and forms to be used to provide the required documentation.

Record all original documentation in a bound field book or other KDOT approved bound record and turn over to KDOT at the end of the project.

At all times, have complete records of all inspections and tests available on site for the Engineer. All records documenting the Contractor's quality control inspections and tests become the property of KDOT upon completion of the work.

Indicate the nature and number of observations made, the number and type of deficiencies found, the quantities approved and rejected, and the corrective action taken in the records. Examples of quality control forms and charts are available in Part V, or Contractors may design their own. Documentation procedures are subject to approval by the Engineer before the start of the work and to compliance checks during the progress of the work.

Maintain control charts on an ongoing basis.

Provide the following test data to the KDOT Project Representative:

- Copies of all test results and control charts on a weekly basis, representing the prior week's production;
- Copies of the quality control summary sheet on a daily basis. Include, as a minimum, mix gradation, binder content, theoretical maximum specific gravity (G_{mm}), air voids (V_a) at N_{des} , percent G_{mm} at N_{ini}

- and N_{max} , voids in mineral aggregate (VMA), voids filled with asphalt (VFA) and dust to effective binder content (D/B) ratio; and
- Copies of all failing test results (based on a moving average of 4 tests, when appropriate). Include all applicable sieves, VMA, VFA, density at N_{ini} and N_{max} , and D/B ratio.

f. Testing Requirements. In the QCP, identify test methods, procedures and equipment proposed for use. Use standard KDOT test methods and properly calibrated measuring and testing equipment as outlined in Part V. Detail any alternative sampling method, procedure or inspection equipment proposed to be used. Such alternatives are subject to review and approval by the DME.

Take all samples for tests and perform in-place tests at random locations, selected according to the Contractor's QCP and at the rates specified in the Sampling and Testing Frequency Chart for Hot Mix Asphalt for Quality Control/Quality Assurance Projects in Appendix B, Part V.

g. Pre-Production Testing Requirements.

(1) The Engineer will observe the Contractor obtaining and splitting the pre-production test section sample into 3 representative portions. Each sample set shall consist of enough material for 2 gyratory specimens, theoretical G_{mm} and ignition burnoff.

(2) Mold 2 gyratory specimens from the 1st sample set immediately, while still hot. Additional heating may be required to raise the temperature of the sample to compaction temperature. Determine G_{mm} , perform ignition burnoff and complete calculations.

(3) Provide the KDOT Field Representative with the 2nd sample set. The KDOT Field Representative will mold 2 gyratory specimens, determine G_{mm} , perform ignition burnoff and complete calculations.

(4) Retain or provide the 3rd sample set to the KDOT District Materials Representative.

(5) The results of the testing will be compared. If Contractor and KDOT field laboratory test results do not compare favorably, the District Materials Laboratory will test their $\frac{1}{3}$ of the sample. This sample will be transported to the District Materials Laboratory, after it has cooled to ambient air temperature. KDOT personnel will reheat the sample to compaction temperature, mold 2 gyratory specimens, determine G_{mm} , perform ignition burnoff and complete calculations. If the 3rd sample set is collected, transported while hot to the District Materials Laboratory and compacted in less than 2 hours, then, at the DME's discretion, the requirement to cool the sample may be waived.

If results are not acceptable to either party, repeat the above steps in **subsections 602.2g.(1) through (5)** for the Contractor's Field Laboratory, KDOT's Field Laboratory, and District Materials Laboratory until the issues may be resolved satisfactorily by all parties.

h. Lot 1 Testing Requirements.

(1) Sequence of Sampling. KDOT field personnel will determine the random truckload for the Contractor for sublots A, B, C and D, and the KDOT verification test.

The verification sample will be sampled and tested by KDOT field personnel. The verification sample shall be randomly taken within the lot and shall not be the same truckload as selected for the Contractor's subplot A, B, C or D.

KDOT field personnel will:

- provide the random spots to sample from behind the paving operations before compaction (KT-25);
- not supply the Contractor the identity of the truckload to be sampled ahead of time;
- notify the Contractor's laboratory of which truck to sample after the aggregate has left the cold feeds, and before the truck is finished loading; and
- determine whether the split sample will be taken from subplot A or B and notify the Contractor.

(2) Split Samples. The Contractor shall:

- obtain a sample large enough to split 3 ways for testing;
- retain and test $\frac{1}{3}$ of the sample;
- supply $\frac{1}{3}$ of the sample to the KDOT field laboratory for testing; and
- supply $\frac{1}{3}$ of the sample to the KDOT District Materials Laboratory for testing.

(3) Results. At a minimum, compare G_{mm} and V_a results. The acceptable differences are 0.019 and 0.5%, respectively. If the results exceed these differences, take an additional split sample in Lot 1 from subplot C or D, as time permits.

If test results do not compare favorably, KDOT and the Contractor will investigate the differences in test results together and take appropriate action. The Contractor's test results will be used for quality control. KDOT Field Laboratory test results and District Materials Laboratory test results will be reported as "information only" samples.

i. Testing Requirements for Lots 2 and Greater.

(1) Take all samples for tests at random locations as designated in the approved QCP at the rates specified in Appendix B, Part V.

Provide the Engineer with the random locations before going to the roadway to determine density or sample the HMA. The Engineer reserves the right to generate the random locations. If the Engineer generates the random locations, the Contractor will be notified before going to the roadway to sample the HMA or determine density.

(2) Conduct the tests for mixture properties, aggregate gradation and binder content on representative portions of the HMA, quartered from the larger sample of HMA. Take a random sample weighing a minimum of 55 pounds from behind the paver and transport it to the test facility, using a method to retain heat to facilitate sample quartering procedures.

(3) Record and document all test results and calculations on data sheets provided by KDOT. Record specific test results on a daily summary sheet provided by KDOT to facilitate the computation of moving test averages. Base moving averages on 4 consecutive test results. Calculations are to be based on the precision displayed on the data sheets. Use "precision displayed" when calculating within Excel. Appendix B, Part V shows the accuracy to "record to" for the tests listed. Include a description of quality control actions taken (adjustment of cold feed percentages, changes in Job Mix Formulas (JMF), etc.) in the Daily Quality Control Summary Sheet. In addition, post and keep current quality control charts, showing both individual test results and moving average values. As a minimum, plot the single test values and the 4 test moving average values, as applicable, on KDOT approved control charts for the mix characteristics shown in **TABLE 602-12**.

(4) If the Contractor and Engineer agree, the procedures shown for sampling, testing and evaluation of Lot 1 in **subsection 602.2h**, may be used for any other Lot produced on the project.

j. Corrective Action. In the QCP, identify procedures for notifying the Engineer when corrective measures must be implemented, and for halting production.

k. Non-Conforming Materials. In the QCP, specifically address how non-conforming materials will be controlled and identified. Establish and maintain an effective and positive system for controlling non-complying material, including procedures for its identification, isolation and disposition. Reclaim or rework non-complying materials according to procedures acceptable to the Engineer. This could include removal and replacement of in-place pavement.

Positively identify all non-conforming materials and products to prevent use, shipment and intermingling with complying materials and products. Provide holding areas, mutually agreeable to the Engineer and Contractor.

602.3 MATERIALS

a. Asphalt Binder. Provide Asphalt Binder that complies with **DIVISION 1200**. Post a legible copy of the latest bill of lading for the Asphalt Binder on or near the gyratory compactor. Use the mixing and compaction temperatures shown on the bill of lading; however, the maximum mixing or compaction temperature is 340°F, unless otherwise approved by the Field Materials Engineer. Notify the Engineer if the mixing or compaction temperature changes.

Exception: The mixing temperature may be increased no more than 10°F above the maximum mixing temperature shown on the bill of lading provided all the following are met:

- The air temperature is below 70°F.
- The plant has not produced mix earlier in the day.
- Do not exceed a mix temperature of 350°F.
- No truck has returned for its second load of the day.

Once a previously loaded truck returns for its next load, reduce the temperature to not higher than the maximum mix temperature shown on the bill of lading, not to exceed 340°F.

b. Reclaimed Asphalt Pavement (RAP) and Recycled Asphalt Shingles (RAS). Provide RAP and RAS that comply with **SECTION 1103**.

c. Aggregates. Provide aggregates that comply with **SECTION 1103**.

d. Combined Aggregates. Provide combined aggregates for the mixes required in the Contract Documents as shown in **TABLE 602-1**.

Mixes may use any combination of aggregate and mineral filler supplements complying with the applicable requirements in **TABLES 1103-1** and **1103-2**.

Provide materials with less than 0.5% moisture in the final mixture.

The maximum quantity of crushed steel slag used in the mix is 50% of the total aggregate weight.

For all mixes used on the traveled way, the maximum quantity of natural sand is 35%.

Natural sand shall be called SSG-1, SSG-2, etc. in the mix design.

Additional requirements for SM-9.5T and SR-9.5T:

- Traveled way mixes shall include a minimum of 40% primary aggregate based on total aggregate weight;
- A minimum of 50% of the plus No. 4 mesh sieve material in the mixture shall be from the primary aggregate;
- A minimum of 45% of the plus No. 8 mesh sieve material in the mixture shall be from the primary aggregate; and
- Primary aggregates are designated as CS-1 (excluding limestone), CS-2 (excluding limestone), CG, CH-1 and CSSL as described in **subsection 1103.2a.(1)**. Primary aggregate requirements do not apply to the mixture used on the shoulder.

e. Contractor Trial Mix Design. A minimum of 10 working days before the start of HMA production, submit in writing to the DME for review and approval, a proposed JMF for each combination of aggregates. For each JMF submitted, include test data to demonstrate that mixtures complying with each proposed JMF shall have properties specified in **TABLE 602-1** for the designated mix type at the Recommended Percent Asphalt (P_{br}). Submit the proposed JMF on forms provided by KDOT. Submit the worksheets used in the design process to include at a minimum the mix properties listed in **TABLE 602-2**. Contact the DME to determine if additional information should be submitted. Provide sufficient material as identified in **TABLE 602-3**. Contact the DME to determine if additional material is needed for additional design checks such as the modified Lottman test (KT-56).

When more than 25% of the mix is comprised of siliceous virgin aggregates and/or RAP, add anti-strip to the mix. The minimum amount of anti-strip required in the mix is 0.01% for every percent of natural sand and RAP in the mix. Thus, if 25% natural sand and 10% RAP is in a mix, then 0.35% anti-strip by weight of virgin asphalt binder is required in the mix.

If during production, the Tensile Strength Ratio (TSR) values (both KDOT and Contractor) exceed 85%, then the Contractor and the DME, working together, may decide on a lower amount of anti-strip.

Submit for the Engineer's review and approval, the test data listed in **TABLE 602-4** for each blend and the proposed JMF. In addition, for mixes containing RAP or RAS, submit for the Engineer's review and approval, the test data listed in **TABLE 602-5** for each blend and the proposed JMF. Submit a mix design for each blend and the proposed JMF as outlined in **TABLE 602-6**.

For each aggregate used in the mix design, determine the specific gravity using KT-6. This may be accomplished while the project is being constructed or anytime during the 12 months preceding the start of construction on a project. If construction has not yet begun, notify the DME 5 working days prior to obtaining the material for the specific gravity test so that companion samples may be obtained at the same time. If construction has already begun on the project, then determine the specific gravity values of the individual aggregates before 10,000 tons of HMA is produced. Provide the test results to the DME within 14 days of sampling the material. If the producer of the aggregate has been required to submit material to KDOT for a new Official Quality test, since the time the Contractor ran the specific gravity tests, then perform KT-6 on the aggregate currently produced. Do not use the specific gravity values obtained from these tests in the mix design calculations for current projects, unless mutually agreeable to both parties. Use the information, as soon as it becomes available, as part of the process to verify and update the "Monthly Hot Mix Aggregate Specific Gravity Values" posted on KDOT's Internet site.

TABLE 602-1: COMBINED AGGREGATE REQUIREMENTS											
Nom. Max. Size Mix Designation	Percent Retained – Square Mesh Sieves									Min. VMA (%)	D/B Ratio
	1 1/2"	1"	3/4"	1/2"	3/8"	No. 4	No. 8	No. 16	No. 200		
SM-4.75A SR-4.75A			0	0-2	0-5	0-10		40-70	88.0-94.0	16.0	0.9 – 2.0
			0	0-2	0-5	0-10		40-70	88.0-94.0	16.0	0.9 – 2.0
SM-9.5A SR-9.5A			0	0-2	0-10	10 min.	33-53		90.0-98.0	15.0	0.6 – 1.2
			0	0-2	0-10	10 min.	33-53		90.0-98.0	15.0	0.6 – 1.2
SM-9.5B SR-9.5B			0	0-2	0-10	10 min.	53-68		90.0-98.0	15.0	0.8 – 1.6
			0	0-2	0-10	10 min.	53-68		90.0-98.0	15.0	0.8 – 1.6
SM-9.5T SR-9.5T			0	0-2	0-10	10 min.	53-68		90.0-98.0	15.0	0.8 – 1.6
			0	0-2	0-10	10 min.	53-68		90.0-98.0	15.0	0.8 – 1.6
SM-12.5A SR-12.5A		0	0	0-10	10 min.		42-61		90.0-98.0	14.0	0.6 – 1.2
		0	0-2	0-10	10 min.		42-61		90.0-98.0	14.0	0.6 – 1.2
SM-12.5B SR-12.5B		0	0	0-10	10 min.		61-72		90.0-98.0	14.0	0.8 – 1.6
		0	0-2	0-10	10 min.		61-72		90.0-98.0	14.0	0.8 – 1.6
SM-19A SR-19A	0	0	0-10	10 min.			51-65		92.0-98.0	13.0	0.6 – 1.2
	0	0-2	0-10	10 min.			51-65		92.0-98.0	13.0	0.6 – 1.2
SM-19B SR-19B	0	0	0-10	10 min.			65-77		92.0-98.0	13.0	0.8 – 1.6
	0	0-2	0-10	10 min.			65-77		92.0-98.0	13.0	0.8 – 1.6

1. The requirements for Coarse Aggregate Angularity (CAA); Fine Aggregate Angularity (FAA); Sand Equivalent (SE); percent RAP; binder grade; Gyrotory compaction revolutions N_{ini} , N_{des} , N_{max} , N_{ini} level of compaction and VFA shall be as shown in the Contract Special Provisions for each mix designation.
2. The flat and elongated particles in the combined coarse aggregate shall not exceed 10% for the total sample.
3. The maximum percent moisture in the final mixture shall not exceed 0.5 for any mix designation.
4. The target air voids (V_a) for any mix designation shall be 4.0% at N_{des} gyrations.
5. The minimum tensile strength ratio (%TSR) shall be 80% for any mix designation.
6. The level of compaction of the mix when compacted to N_{ini} gyrations shall be less than the percent of the G_{mm} shown in the Contract Special Provision, and when compacted to N_{max} gyrations shall be a maximum of 98.0% of the G_{mm} .

TABLE 602-2: MIX PROPERTIES			
Property	Abbreviation	Test Method	Additional Information
Air Voids	V_a	KT-15 & KT-58	Calculated from G_{mm} and G_{mb} . Run at the P_{br} .
Recommended Percent Asphalt	P_{br}		Produce a mix with a V_a of 3.5% to 4.5%.
Theoretical Maximum Specific Gravity	G_{mm}	KT-39	Rice Test.
Percent Tensile Strength Ratio	%TSR	KT-56	Run test at P_{br} or at 0.3% to 0.5% less than P_{br}
Sand Equivalent	SE	KT-55	
Bulk Specific Gravity of HMA	G_{mb}	KT-15	Compacted Mix Property.
Percent G_{mm} at N_{ini} and N_{des} and N_{max}	$\%G_{mm} @ N_{ini}$ $\%G_{mm} @ N_{des}$ $\%G_{mm} @ N_{max}$	KT-15	Use G_{mm} value from KT-39. Calculated from Gyrotory Compaction height data, G_{mm} , and G_{mb} .
Voids in Mineral Aggregate	VMA	KT-15 & KT-6	Calculated from G_{mb} , G_{sb} , P_b .
Voids Filled with Asphalt	VFA		Calculated from VMA and $V_a @ N_{des}$.
Coarse Aggregate Angularity	CAA	KT-31	
Fine Aggregate Angularity	FAA	KT-50	

Formulas for calculations are in the Superpave Volumetric Mixture Design and Analysis Handbook.

TABLE 602-3: MATERIAL SUBMITTALS			
Submittal	Quantity	Description	Additional Information
Aggregate for KT-15	3 Samples	Sized for 6 inch Plugs	Comply with Job Mix Gradation.
Aggregate for KT-39	2 Samples	Sized for G_{mm} Testing	Comply with Job Mix Gradation.
Binder for KT-15	As Needed	Sized for 3 Plugs at P_{br}	
Binder for KT-39	As Needed	Sized for 2 G_{mm} Tests	
Each Aggregate for KT-6	As Needed	Specific Gravity Test	
Uncompacted HMA Sample	35 lbs	Cool sample to room temperature	If transported hot and compacted within 2 hours, then requirement to cool sample may be waived by the DME.
Gyratory Plugs at N_{max}	2 Plugs	Compacted at P_{br}	Compacted to N_{max} .

TABLE 602-4: TEST DATA SUBMITTALS	
Submittal	Information
Asphalt Binder	Source, Grade, Specific Gravity, Mixing and Compaction Temperature from the Producer of the asphalt binder.
Each Aggregate	Source and Producer, including Legal Description.
Gradation of Each Aggregate	Percentage Retained to nearest 1% (except nearest 0.1% for No. 200 sieve) Derive RAP gradation after residual binder is removed. Derive RAS gradation after residual binder is removed or from the Shingle Aggregate Gradation table in SECTION 1103 .
Material Proportioning	Proportion of each material is shown in percentage of aggregate.
Composite Gradation	Based on Gradation of Each Aggregate and Material Proportioning.
Composite Gradation Plot	Plotted on KDOT Form 712 (0.45 power graph paper).
Asphalt Binder Added	Percentage to nearest 0.01% based on total weight of the mixture.
Aggregate	Percentage of flat and elongated particles in the coarse aggregate, CAA and FAA.
%TSR	Percent Tensile Strength Ratio of the Mixture (Modified Lottman Test).
Sand Equivalent	SE for the combined virgin aggregates.

TABLE 602-5: RAP AND RAS TEST DATA SUBMITTALS	
Submittal	Information
RAP and RAS	Source and location where RAP will be obtained. Source and location where RAS will be obtained.
RAP Aggregate	Bulk Specific Gravity (G_{sb}). Use the G_{sb} provided on the Contract Special Provision. If no value is provided, the Effective Specific Gravity (G_{se}) shall be calculated as shown in subsection 5.10.4, Part V and used as the G_{sb} .
RAS Aggregate	Bulk Specific Gravity (G_{sb}). The Effective Specific Gravity (G_{se}) shall be calculated as shown in subsection 5.10.4, Part V and used as the G_{sb} .
Asphalt Binder Content of RAP Asphalt Binder Content of RAS	Determined from ignition oven analysis using KT-57.
RAP G_{mm} RAS G_{mm}	Determined by KT-39.
Asphalt Binder Specific Gravity	Specific Gravity of the asphalt binder in the RAP and RAS (G_b) shall be set equal to 1.035.
Corrected Asphalt Binder Content of the total recycled mixture	Determined from ignition oven analysis using KT-57.

TABLE 602-6: MIX DESIGN TEST DATA SUBMITTALS	
Submittal	Information
Minimum of 2 Mix Designs	As a minimum, 1 mix design at the P_{br} and 1 mix design at 0.3% to 0.5% below the P_{br}
G_{mm}	Determined at each binder content.
Individual and Bulk Specific Gravity Tests	Provide results for a minimum of 2 specimens at each binder content.
Percent Air Voids	Provide % V_a in the mixture for each binder content when compacted to N_{ini} , N_{des} and N_{max} gyratory revolutions along with copies of the Gyratory graphs.
Percent VMA	Provide %VMA at each binder content. (Note: The Contractor is cautioned that plant produced material generally yields a mixture with less VMA than predicted by the design. In such case, the design VMA should be increased above the specified minimum accordingly.)
D/B Ratio	Calculate to the nearest 0.1% at each binder content.

f. Additives. Provide Warm Mix Asphalt (WMA) additives or processes that comply with **SECTION 1203**. The Contractor is permitted to use WMA, unless otherwise shown in the Contract Documents.

For mixes containing Warm Mix Asphalt (WMA) additives, submit for the Engineer’s review and approval, the additive or process used, the recommended rate of application, and the temperature ranges for mixing and compaction.

Mixing temperature range is provided by the Asphalt Binder Supplier. When using WMA, the mixing temperature may be reduced no more than 30°F for WMA water foaming processes, and no more than 70°F for WMA chemical and organic additives. The minimum mixing temperature for WMA is 220°F.

602.4 CONSTRUCTION REQUIREMENTS

a. Plant Operation. Adjust all plant operations to operate continuously.

(1) Preparation of the Asphalt Binder. Heat the asphalt binder to within a range as specified in **SECTION 601**. When heating the asphalt binder to the specified temperature, avoid local overheating. At all times, provide a continuous supply of the asphalt binder to the mixer at a uniform temperature. Asphalt binder received from the refinery at temperatures less than 375°F may be used as received, if the requirements regarding the reheating of asphalt binder in **SECTION 601** are met.

(a) Commingling of Asphalt Binders. Do not add or commingle asphalt binders from 2 or more sources into a storage tank. If this occurs, the contents of the storage tank are considered contaminated. Do not use the contents of the storage tank on the project, except as follows: It is permissible, at the Contractor’s option, to thoroughly mix the contents of the tank and request sampling of the mixture. Submit the sample to the MRC for testing. Do not use the asphalt binder until approved, and when needed, a new mix design evaluation is completed.

(b) Asphalt Binder Sources. Before changing asphalt binder sources on a project, obtain approval from the DME. A new JMF may be required.

(c) Anti-Strip Additives. If liquid anti-strip additives are added at the Contractor’s plant, install a “totalizer” to monitor the quantity of anti-strip additive being added. The Engineer may approve alternative methods for including anti-strip additives in a batch plant. If added at the plant, the anti-strip will be added in line with the asphalt binder as it is being transferred from the transit unit to the asphalt binder storage tank. Provide a method for the Engineer to monitor the percent of additive being added.

If hydrated lime is added, mix it in an approved pug mill to coat the combined aggregates. Moisten the combined virgin aggregate to a minimum of 3% above the saturated surface dry condition prior to, or during the addition of the hydrated lime.

(d) WMA Additives. If WMA additives are added at the Contractor’s plant, install a “totalizer” to monitor the quantity of WMA additive being added. The Engineer may approve alternative methods for including chemical and organic WMA additives in a batch plant. If added at the plant, chemical and organic WMA additives will be added in line with the asphalt binder as it is being transferred from the transit unit to the asphalt binder storage tank. Provide a method for the Engineer to monitor the percent of additive being added.

(2) Preparation of Mineral Aggregate. When the mineral aggregate is composed of 2 or more ingredients, combine as shown in the approved JMF.

(a) Temperature Requirements. Dry the aggregate for the mixture and heat to a temperature to obtain an asphalt-aggregate mixture temperature immediately after mixing within the 75 to 150 second Saybolt viscosity range of the asphalt binder used. Obtain the temperature for this viscosity range from the MRC or the Asphalt Binder Producer. No mixing or compaction temperatures are to exceed 340°F without approval from the Field Materials Engineer. The minimum temperature may be revised by the DME provided it is demonstrated that satisfactory results may be obtained at a lower temperature. In such event, deliver the HMA to the paver at a temperature sufficient to allow the material to be satisfactorily placed and compacted to the specified density and surface tolerance requirements.

(3) Preparation of HMA. Introduce asphalt binder into the prepared aggregate in the proportionate amount determined by the P_{br} in the JMF.

(a) Basis of Rejection. HMA will be rejected if the aggregate, as it is discharged from the drum or the pugmill, contains sufficient moisture to cause foaming of the mixture, or if the temperature of the aggregate is such that the asphalt-aggregate mixture temperature is outside the range specified in **SECTION 601**.

(b) Mixing Time. Operate drum mixers at a rate to provide uniform aggregate coating in a continuous operation. For batch and continuous type plants, the minimum wet mixing time is 40 seconds. In all cases, mix a sufficient time to produce a uniform mixture in which all the aggregate particles are thoroughly coated. On batch plants, begin the timing at the start of the asphalt binder introduction into the pugmill, and end upon the opening of the discharge gate. For continuous flow plants, mixing time in seconds shall equal:

[pugmill dead capacity in pounds] divided by [pugmill output in pounds per second].

(c) Manufacturer's Specifications. Operate all drying, pumping and mixing equipment within the limits specified by the manufacturer, unless it can be demonstrated to the satisfaction of the Engineer that such limits may be exceeded without detriment to the HMA.

(d) Batch Operation. Coordinate HMA batchers (Gob Hoppers) with the plant production rate at all times so the hopper is more than $\frac{3}{4}$ full before the gates open, and the gates close before material can drop through the gob hopper directly into the surge bin, weigh hopper or truck.

(e) Wasted Material. Wasted material is not measured for pay.

If after an interruption of production, the drum-mixer contains cold, uncoated or otherwise unsuitable material, waste material through a diversion chute. In a continuous or batch plant drier, waste unsuitable material through the pugmill.

At the end of a production run, waste any segregated material in the cone of the storage bin.

(4) End of Day Quantities. At the end of each day of production provide the Engineer with a document signed by the Plant Foreman or the Project Manager listing the dry weight of each aggregate, mineral filler, RAP, and WMA chemical or organic additive; the tons of asphalt binder, the tons of anti-strip agent used for the project during the day, and the tons of water used in the WMA foaming process. The dry weight is the tons of the material less the water content.

b. Road Surface Preparation.

(1) Preparation of Earth Subgrade. Do not place any surfacing material on any section, until the ditches and drains along that section are constructed to effectively drain the highway, and the base or subgrade is trimmed to the line, grade and typical cross-section as shown in the Contract Documents.

Do not deposit any material until the subgrade or base has been checked and approved by the Engineer.

Maintain the subgrade as prepared until it is covered with the base course. Repair any defects which may develop, at the Contractor's expense, to the satisfaction of the Engineer.

Protect the subgrade from damage when handling materials, tools and equipment. Do not store or stockpile materials on the subgrade. Do not place material or lay pavement on a frozen or muddy subgrade, or when it is raining or snowing.

Lightly spray the subgrade or base with water to obtain a thoroughly moistened condition when the HMA is deposited on it. Lightly scarify, where necessary. Do not puddle water on the grade. Disturb the originally compacted crust or top portion of the subgrade as little as possible.

(2) Preparation of an Existing Asphalt Pavement. Clean the surface to remove all foreign material and broom to remove dust. Excavate areas shown in the Contract Documents to be patched to a depth directed by the Engineer. Fill with HMA and compact.

(3) Preparation of an Existing Concrete or Brick Pavement. Clean all foreign material and broom to remove dust. Clean and fill cracks and joints, and construct surface leveling as shown in the Contract Documents.

(4) Tack Coat. Prior to placing the HMA, apply a tack coat to the existing surface, as shown in the Contract Documents. When warranted by weather conditions, the Engineer may authorize a change in the asphalt for tack coat. When such changes are made, the price per ton of material being used will be the unit price bid for the material designated in the contract plus or minus the difference in the invoice price per ton of the 2 materials at the refinery as determined at the time of application.

c. Weighing Operations. See SECTION 109 for details regarding weighing operations.

d. Hauling Operations. Schedule operations to minimize hauling over a surface course.

Deliver HMA to the paver at a temperature sufficient to allow the material to be placed and compacted to the specified density and surface tolerance.

e. Paving Operations. Except when placing SM-4.75A, SM-9.5A or SR-9.5A asphalt mixtures, remix the material transferred from the hauling unit, prior to placement. Use equipment such as a mobile conveyor, material transfer device, shuttle buggy material transfer vehicle, material transfer paver or paver with remix conveyor system. After starting the project with the equipment listed above, and after producing HMA pavement density within the limits specified in TABLE 602-7, the Engineer will consider other types of equipment or modifications to pavers that will produce less segregation. The use of equipment as noted above shall not relieve the Contractor of the responsibility to comply with TABLE 602-7. The Engineer will check the pavement for longitudinal streaks and other irregularities. Make every effort to prevent or correct any irregularities in the pavement, such as changing pavers or using different and additional equipment.

Do not raise (dump) the wings of the paver receiving hopper at any time during the paving operation. The Engineer may waive this requirement if it is determined that raising (dumping) the wings will not produce detrimental segregation. If segregation or irregularities in the pavement surface or density are noted, review the plant, hauling and paving operations and take corrective action. The recommendations made in KDOT's "Segregation Check Points" should reduce the segregation and irregularities to an acceptable level. Copies of KDOT's "Segregation Check Points" may be obtained from the KDOT District Office or Field Engineer.

Spread the HMA and finish to the specified crown and grade using an automatically controlled HMA paver. Operate the paver at a speed to provide a uniform rate of placement without undue interruption. At all times, keep the paver hopper sufficiently full to prevent non-uniform flow of the HMA to the augers and screed.

If the automatic grade control devices break down, the Engineer may allow the paver to operate to the close of the working day, provided the surface is satisfactory. Do not operate the paver without working automatic control devices upon another lift that was laid without automatic controls.

(1) Surface Quality. Spread the HMA without tearing the surface. Strike a finish that is smooth, free of segregation, true to cross section, uniform in density and texture and free from surface irregularities. If the pavement does not comply with all of these requirements, plant production and paving will be suspended until the deficiency is corrected.

The Engineer will check segregation and uniformity of density using methods outlined in Section 5.8.3 - Segregation Check Using the Nuclear Density Gauge, Part V. For shoulders with a plan width of less than or equal to 3 feet, and placed at the same time as the traveled way, do not take nuclear density readings on the shoulder nor within 1 foot of the shoulder unless the pavement section is uniform across the entire roadway. The acceptable criteria for density uniformity are in TABLE 602-7.

TABLE 602-7: SEGREGATION AND UNIFORMITY OF DENSITY CHECK		
Mix Designation	Maximum Density Range (highest minus lowest)	Maximum Density Drop (average minus lowest)
All	4.4 lbs./cu. ft.	2.2 lbs./cu. ft.

Whenever the results from 2 consecutive density profiles fail to comply with both of the requirements listed in TABLE 602-7, plant production and paving will be suspended. Follow the procedures listed in the Profile Evaluation

Subsection of Section 5.8.3-Segregation Check Using the Nuclear Density Gauge, Part V until production may be resumed.

Joint density testing and the associated requirements listed below do not apply for HMA lift thicknesses less than or equal to 1 inch.

Evaluate the longitudinal joint density using methods outlined in Section 5.8.4-Joint Density Evaluation Using the Nuclear Density Gauge, Part V. Although it is the Contractor’s responsibility to perform the joint density evaluation, the Engineer may make as many independent joint density verifications as deemed necessary at the random sample locations. The Engineer’s results will be used for acceptance for joint density, whenever available. The acceptable criteria for joint density are in **TABLE 602-8**.

TABLE 602-8: JOINT DENSITY REQUIREMENTS	
Nuclear Gauge Readings	Requirement
Interior Density minus Joint Density	≤ 3.0 lbs./cu. ft.
OR	
Joint Density	≥ 90.00% of G _{mm}

If the results of 2 consecutive density profiles fail to comply with **TABLE 602-8**, the plant production and paving operations will be suspended. Follow the procedures listed in the Joint Evaluation Subsection of Section 5.8.4-Joint Density Evaluation Using the Nuclear Density Gauge, Part V, until production may be resumed.

(2) Leveling Courses. In general, spread leveling course mixtures by the method to produce the best results under prevailing conditions to secure a smooth base of uniform grade and cross section. The leveling course may be spread with a properly equipped paver or motor grader.

(3) Lift Thickness. Except for leveling courses or when shown otherwise in the Contract Documents, **TABLE 602-9** applies. The Engineer may adjust lift thickness to utilize the most efficient method of acquiring specified density and surface quality. The minimum lift thickness for any HMA mixture is 3 times the nominal maximum aggregate size, unless otherwise designated in the Contract Documents or approved by the Engineer.

TABLE 602-9: NOMINAL COMPACTED THICKNESS	
Lift	Maximum Nominal Compacted Thickness
Surface	2 inches
Base	4 inches

(4) Grade Control. Achieve grade control by use of 1 or more of the following grade reference devices. Approval of any of these devices will be based upon satisfactory performance.

(a) Traveling Stringline. Attach a traveling stringline or ski type attachment, a minimum length of 30 feet, to the paver and operate parallel with its line of travel.

(b) Reference Shoe. Attach a short reference shoe or joint matching device to the paver for control in matching surface grades along longitudinal joints.

(c) Erect Stringline. Use an erected stringline consisting of a tightly stretched wire or string offset from and parallel to the pavement edge on 1 or both sides. Erect the stringline parallel to the established pavement surface grade and support at intervals as necessary to maintain the established grade and alignment.

(d) Stringless Paving. Control line, grade and pavement cross-section as shown in the Contract Documents. Use electronic guidance systems that meet the requirements and tolerances listed in **SECTION 802**. Horizontal control is guided by GPS. Vertical control is guided by Total Stations. GPS will not be allowed for Vertical control.

When paving on a fresh subgrade that has not been trimmed by an automatically controlled machine, use an erected stringline or stringless paving to establish grade. Use either of these options on the first or second lift. When directed by the Engineer, use an erected stringline or stringless paving to match grade control points such as bridges.

(5) Compaction of Mixtures. Uniformly compact the HMA as soon after spreading and strike-off as possible without shoving or tearing. Use self-propelled rollers operated at speeds slow enough to avoid displacement of the HMA. Equipment and rolling procedures which result in excessive crushing of the aggregate are prohibited. Use a sufficient number and weight of rollers to compact the HMA to the required density, using a minimum of 2 rollers. If the hot mix plant is operating at over 275 tons per hour, use a minimum of 3 rollers. See

subsections 602.4e.(6) for exceptions to the minimum number of rollers. Perform final rolling with a steel roller unless otherwise specified. On the final pass, operate finishing, vibratory rollers in the static mode.

Coordinate the frequency, amplitude and forward speed of the vibratory roller to achieve satisfactory compaction without objectionable undulations. For HMA lifts with a compacted thickness less than 1¼ inch, operate vibratory rollers in the static mode.

Keep rollers in operation as necessary so all parts of the pavement receive substantially equal compaction at the proper time. The Engineer will suspend HMA delivery to the project at any time proper compaction is not being performed.

Remove, replace with suitable material and finish according to these specifications any mixture that becomes loose, broken, mixed with foreign material or which does not comply in all respects with the specifications.

(6) Density Requirements.

(a) For mixes with a specified thickness greater than or equal to 1 ½ inches:

For lots 1 and 2, control density as shown in **subsection 602.4e.(6)(b)**. Before beginning production, the Contractor has the option to accept the pay adjustment for density on both Lots 1 and 2, or only Lot 2. If the Contractor chooses to accept the pay adjustments for density on both Lots 1 and 2, or only Lot 2, control the density as shown in **subsections 602.4e.(6)(a)(i-ii)**. If the Contractor chooses to accept pay adjustment for density on Lot 1, the pay adjustment can not be rejected on Lot 2.

(i) HMA Overlay. For lots 3 and greater, the lot density requirements and appropriate density pay adjustment factors are shown in **subsection 602.9b**, as the percent of the G_{mm} value based on the average of the density tests. The standard lot size is 10 density tests. Smaller lot sizes may result as outlined in **TABLE 602-10**. Normally, the G_{mm} value used to calculate the density percentage is the average value of all G_{mm} tests conducted the same day the lot was placed and compacted. If less than 3 G_{mm} values were obtained that day, use the moving average value (last 4 tests prior to the end of the day). When starting a mix and less than 4 G_{mm} values have been determined, use the average value of those available at the end of each day.

(ii) HMA Surface, HMA Base and HMA Pavement. For lots 3 and greater, the lower specification limit (LSL) value for density is given in **subsection 602.9c**, along with the appropriate density pay adjustment factor equations. The LSL value is given as a percentage of G_{mm} . Lot density is determined using the measured density values for all sublots in a lot. The standard lot size is 10 density tests. Smaller lot sizes may result as outlined in **TABLE 602-10**. Normally, the G_{mm} value used to calculate the density percentage is the average value of all G_{mm} tests conducted the same day the lot was placed and compacted. If less than 3 G_{mm} values were obtained that day, use the moving average value (last 4 tests prior to the end of the day). When starting a mix and less than 4 G_{mm} values have been determined, use the average value of those available at the end of each day.

(b) For mixes with a specified thickness less than 1½ inches:

These mixes will not have a density pay adjustment. Control density using an approved rolling procedure with random nuclear gauge density determinations. Include a method for controlling density in the QCP.

Designate a "Compaction Foreman". This person shall control compaction procedures, review nuclear gauge results as they are obtained, adjust compaction procedures as needed to optimize compaction and report any changes in the compaction process and results of nuclear gauge testing to the Engineer. The compaction foreman may also be the nuclear gauge operator. The nuclear gauge operator shall continuously monitor compaction procedures. As a minimum, take 10 random nuclear gauge density determinations per day and report results to the Engineer. Throughout the day, nuclear gauge results shall be available for review by the Engineer. The compaction foreman shall document at a minimum of once every 2 hours that the approved rolling sequence is being followed. Documentation includes roller passes, the mat temperature at each pass, amplitude setting of rollers and roller speed. Provide the documentation to the Engineer.

Determine and periodically update an approved rolling procedure and periodically, as outlined in this section. As a minimum, evaluate the initial rolling procedure using 3 rollers. If the hot mix plant is operating at over 275 tons per hour, use a minimum of 4 rollers in the initial evaluation. Operate vibratory rollers according to **SECTION 151**. Evaluate HMA paver screed operation with the nuclear gauge at various vibration settings. For screed evaluation, take the nuclear gauge readings directly behind the screed and before rolling. The Compaction Foreman and Engineer

will evaluate the densities obtained with the various roller combinations and screed settings to determine the initial approved rolling procedure.

Together, the Compaction Foreman and Engineer will determine when new rolling procedures are required. HMA production may be stopped by the Compaction Foreman or Engineer whenever rolling is not being performed according to the approved rolling procedure.

(c) For all lots, achieve the maximum density before the temperature of the HMA falls below 175°F. When using WMA, achieve the maximum density before the temperature of the WMA falls below 165°F. Do not crush the aggregate. When the mat temperature falls below 175°F or 165°F for WMA, roller marks may be removed from the mat with a self-propelled static steel roller or an oscillating roller operating in either the static mode or in the oscillating mode.

Daily Production (tons)	Number of Sublots	No. of Cores or Nuclear Density Tests**	No. of Verification Cores or Nuclear Density Tests**
0-599	3*	6*	3*
600-999	4*	8*	4*
1000 or more	5	10	5

*Minimum number for mixes with a specified thickness of 1½ inches or greater: The Contractor may choose to obtain the number required for 1000 or more tons. If the Contractor chooses to test 5 sublots (10 tests), KDOT will obtain 5 verification tests.

**For mixes with a specified thickness less than 1½ inch: Verification testing may be performed, but is not required. Additional testing may be performed by the Contractor. A minimum of 10 tests are required.

(7) Contact Surfaces. Coat contact surfaces of curbing, gutters, manholes and similar structures with a thin uniform coating of asphalt material. Place the HMA uniformly high near the contact surfaces so that after compaction it shall be approximately ¼ inch above the edge of such structures.

(8) Adjustment of Manholes (Set Price). When required, this work will be performed and paid for under **SECTION 816**.

(9) Construction Joints.

(a) Transverse Construction Joints. Use a method of making transverse construction joints to provide a thorough and continuous bond, provide an acceptable surface texture and meet density requirements. Do not vary the surface elevation more than 3/16 inch in 10 feet, when tested longitudinally across the joint. When required, repair the joints or paving operations will be suspended.

(b) Longitudinal Joints. Construct well bonded and sealed longitudinal joints to obtain maximum compaction at the joint. If deemed necessary by the Engineer to properly seal the joint, apply a light coat of asphalt emulsion or asphalt binder to the exposed edge before the joint is made.

Before placing the fresh HMA against a cut joint or against old pavement, spray or paint the contact surface with a thin uniform coat of asphalt emulsion or asphalt binder. Where a finishing machine is used, make the longitudinal joint by depositing a sufficient amount of HMA to form a smooth and tight joint.

Offset the longitudinal joint in successive courses by 6 to 12 inches. Comply with traffic lane edges for the width of the surface of top course placement.

(10) Shoulder Surfacing and Widening. When the placement width of shoulders or uniform width widenings is less than can be accomplished with a regular paver, spread each course with a mechanical spreading device.

(11) Rumble Strips. When designated, construct rumble strips according to the Contract Documents.

f. Maintenance of Traffic. Maintain traffic according to **DIVISION 800** and the following:

Maintain one-way traffic, and restrict traffic speeds to 20 miles per hour in the vicinity of workers, unless otherwise designated. Use pilot cars to lead traffic through the area of paving and rolling operations, and if directed, through a curing area. The use of flaggers is allowed through patching operations, unless the patching area or distance between flaggers exceeds ½ mile, in which case the use of a pilot car shall be required. On overlay projects with 2 lanes or more in each direction for traffic use, the Engineer may waive the pilot car requirements.

Station one flagger ahead of the application of the tack coat and one flagger ahead of the area being protected from traffic. Take adequate protection for traffic on side roads approaching the tack area.

g. Treatment of Adjacent Areas. Pave sideroads, entrances and turnouts for mailboxes as shown in the Contract Documents. Overlay all widening areas designated in the Contract Documents or ordered by the Engineer.

h. Pavement Smoothness. Evaluate pavement smoothness according to **SECTION 603** and the following:

TABLE 602-11: MAXIMUM VARIATION OF THE SURFACE	
Length (feet)	Maximum Variation of the Surface (inches)
10	3/16
25	5/16

Correct all humps or depressions exceeding the specified tolerance by removing the defective work and overlaying with new material, or by other means approved by the Engineer. All necessary corrections are at the Contractor's expense.

602.5 PROCESS CONTROL

a. General. Establish gradation limits and proportions for each individual aggregate, mineral filler and RAP and RAS, when applicable. Specify the limits and proportions such that the material produced complies with the applicable requirements of the designated mix type. The Contractor is responsible for all process control operations including testing. At no time will KDOT's representative issue instructions to the Contractor or producer as to setting of dials, gauges, scales and meters. KDOT will collect and test verification samples and assurance samples and inspect the Contractor's quality control operations.

b. JMF Adjustments. Produce a mixture of uniform composition closely complying with approved design JMF to obtain the specified properties when compacted. If, during production, results from quality control tests demonstrate a need to make adjustments to the mix design, then make adjustments to the design JMF single point gradation and binder content to achieve the specified properties. The JMF adjustments shall produce a mix that complies with **TABLE 602-1** for the specified mix designation. When necessary, adjust on a subplot basis. Report the new JMF to KDOT's field representative and the DME before making such changes, and submit a new mix design for review and approval if required by the DME.

c. Specification Working Ranges. Establish acceptable limits for field test results by applying the tolerances shown in **TABLE 602-12** to the JMF or adjusted JMF for binder content. Establish acceptable limits for the other listed mix characteristics by applying the tolerances shown in **TABLE 602-12** to the requirements of **TABLE 602-1**.

TABLE 602-12: SPECIFICATION WORKING RANGES (QC/QA)				
Mix Characteristic	Tolerance from JMF			
	Single Test Value	Plot	4 Point Moving Average Value	Plot
Binder Content	±0.6%	*	±0.3%	*
Mix Characteristic	Tolerance for Specification Limits			
	Single Test Value	Plot	4 Point Moving Average Value	Plot
Gradation (applicable sieves in TABLE 602-1)	N/A	*	zero tolerance	*
Air Voids @ N _{des} gyrations	±2.0%	*	N/A	
Voids in Mineral Aggregate (VMA)	1.0% below min.	*	zero tolerance	*
Voids Filled with Asphalt (VFA)	N/A		zero tolerance	*
Course Aggregate Angularity (CAA)	zero tolerance		N/A	
Sand Equivalent (SE)	zero tolerance		N/A	
Fine Aggregate Uncompacted Voids (FAA)	zero tolerance		N/A	
%Tensile Strength Ratio (%TSR)	zero tolerance	*	N/A	
Density @ N _{ini} and N _{max}	N/A		zero tolerance	
Dust to Effective Binder (D/B) Ratio	zero tolerance	*	zero tolerance	*

* Plot data according to **subsection 106.4**.

For gradations, as a minimum, plot the No. 4, 8, 30 and 200 sieves.

Plot G_{mm} to third decimal point.

Indicate Job Mix Formula (JMF) and specification working range limits for single test results on the control charts using a green ink dotted line.

Indicate the specification working range limits for the 4-point moving average results with a green ink solid line.

d. Mixes with Reclaimed Asphalt Pavement (RAP). The intent of this section is to prevent more RAP going into a mix than is allowed in the Contract Documents. Totalizers are used to determine the %RAP in mix; however, this does not preclude the Engineer from using other methods for determining the %RAP in a mix.

Provide the Engineer with the totalizer readings at the end of each day of production. These shall include the final daily readings for the RAP, virgin aggregates and asphalt binder.

The %RAP will be checked a minimum of twice a day by the Engineer. Take the readings a minimum of 2 hours apart and a maximum of 6 hours apart. Do not take the readings within the first hour of start-up as adjustments to the plant are most frequent within this time frame.

Calculate RAP percentages using the plant totalizers for the virgin aggregates (AGG_v), and the RAP as follows:

$$\text{Equation A: } \% \text{RAP} = \frac{\text{RAP} * 100}{\text{RAP} + \text{AGG}_v}$$

%RAP is the percent RAP in the total aggregates (Virgin and RAP) rounded to the nearest tenth.

RAP is the difference between the current and last reading of the RAP totalizer in tons.

AGG_v is the difference between the current and last reading of the Virgin Aggregate totalizer in tons.

%RAP is considered out of compliance when any of the following occurs:

- Any single test exceeds the maximum percentage allowed by specs by 3%.
- The 4-point moving average exceeds the maximum percentage allowed by specifications.

Actions to be taken if the %RAP is out of compliance:

- If any single test exceeds 3% of the maximum allowed %RAP stop production, perform the “0 check run” on the belts in the presence of the Engineer, and make adjustments to correct the discrepancy.
- If the 4-point moving average exceeds the maximum allowed %RAP three consecutive times, stop production, perform the “0 check run” on the belts in the presence of the Engineer, and make adjustments to correct the discrepancy.

- If the 4-point moving average exceeds the maximum allowed %RAP by more than 1% then the Contractor will be assessed the following penalty.

Equation B:
$$\text{Contract Deduct} = \frac{\text{BP} * \text{Q} * (\% \text{RAP}_4 - \% \text{RAP}_{\text{max}})}{100}$$

Contract Deduct is the Dollar amount to be subtracted from the contract.

BP is the Bid Price of the mix.

Q is the Quantity, in tons, of material represented by the 4-point moving average. This value shall be based on the weigh tickets taken from the time of the 1st test of the 4-point moving average through the time of 4th test.

%RAP₄ is the 4-point moving average of %RAP.

%RAP_{max} is the Maximum %RAP from the Project Special Provision.

Contract Deducts for RAP will be an item added to the contract.

Any time production is stopped due to non-compliant %RAP, restart the 4-point moving average provided the belt had the “0 check run” performed in the presence of the Engineer, and adjustments were made to the mix proportioning to correct previous discrepancies. The initial start-up at the beginning of each work day does not constitute a stop in production due to non-compliant %RAP.

If at any time the Contractor chooses to stop production in order to correct discrepancies in the mix proportioning concerning the %RAP, the most recent data (not to exceed 4 points) will be averaged. If the average exceeds the maximum allowed %RAP by more than 1% then a Contract Deduct will be assessed as calculated above with the following substitutions:

In the case where less than 4-points are available for the 4-point moving average, the most recent test is substituted for the 4th test, and the %RAP₄ may be a single test, a 2-point moving average or a 3-point moving average.

602.6 COMPACTION TESTING

a. General. Make the density determination of the compacted mixture using test results on random samples selected by the Contractor or Engineer (see **subsection 602.2i.(1)**) from each lift placed. Select sites according to the approved QCP. Take the nuclear density tests or core samples before placement of the next lift and before opening to construction or public traffic, and no later than the next working day following the date of placement.

Exception to coring after any traffic on the overlay. Do not use this procedure more than twice on any one project or tied projects, unless approved by the Engineer. The Contractor may request re-evaluation by coring. (Testing and coring shall be subsidiary items.) When coring is requested, follow these procedures for the lot under re-evaluation.

(1) Immediately prior to coring, determine nuclear gauge densities in the presence of the Engineer in the locations previously tested. The average nuclear gauge density after traffic will be determined. A Contractor density correction factor will be calculated as follows: the average nuclear gauge density after traffic minus the average nuclear gauge density before traffic. If the calculated Contractor density correction factor is a negative value, the Contractor’s density correction factor will be set equal to zero (normally the density correction factor will be a positive number).

(2) Immediately before coring, nuclear gauge densities will be determined by the Engineer in the presence of the Contractor in the locations previously tested. The average nuclear density after traffic will be determined. A KDOT density correction factor will be calculated as follows, the average nuclear gauge density after traffic minus the average nuclear gauge density before traffic. If the calculated KDOT density correction factor is a negative number, KDOT’s density correction factor will be set equal to zero.

(3) Determine the Traffic Density Correction Factor. It will be the larger of the Contractor’s density correction factor or KDOT’s density correction factor determined in **subsections 602.6a.(1)** and **(2)**.

(4) With the Engineer present, obtain 1 core from each of the Contractor and KDOT nuclear gauge locations. Mark each core as they are taken. Take the cores to KDOT’s field laboratory for drying and evaluation. Together, the Contractor and Engineer will determine the density of each core. Determine the corrected core density for each Contractor and KDOT core as follows: the core density minus the Traffic Density Correction Factor.

(5) Using the corrected Contractor core densities and the corrected KDOT core densities, the Engineer will re-evaluate this lot using the procedures outlined in **subsection 602.9**. Based on this re-evaluation, the Engineer will inform the Contractor of the lots disposition and density pay adjustment factor.

For shoulders with a plan width of less than or equal to 3 feet and placed at the same time as the traveled way, the density pay adjustment factors for the traveled way applies. Acceptance of or pay adjustment for density on all shoulders with a plan width greater than 3 feet and any shoulder not placed at the same time as the traveled way shall be according to **subsection 602.9**.

A lot consists of a day's production for each lift placed and contains the number of density locations as outlined in **TABLE 602-10**. Base lot acceptance on 2 test results from each subplot unless the Engineer's results (1 test per subplot) are used. V_a lots and density lots are normally of different sizes.

If the lane being placed is to be opened to traffic that day, the Engineer and the Contractor may predetermine the subplot size based on anticipated production. If actual production does not meet anticipated production, the subplot size will be adjusted. The number of tests shall be as outlined in **TABLE 602-10**.

The minimum number of density tests is as listed in **TABLE 602-10**. The Contractor has the option to take additional tests to provide 10 test results to determine payment. The density pay adjustment factors are computed using formulas in **subsection 602.9**. The density pay adjustment factors do not apply to sideroads, entrances, crossovers and other incidental surfacing.

b. Nuclear Density Tests (For mixes with a specified thickness of 1½ inches or greater.) Take 2 nuclear density tests at random within each subplot. The Engineer will take 1 random nuclear density verification test per subplot. Perform nuclear density testing to be used in the determination of the traveled way pay adjustment factors and control of shoulder density. Do not take nuclear gauge readings within 1 foot of a longitudinal joint or edge, nor within 20 feet of a transverse joint. For shoulders with a plan width of less than or equal to 3 feet, and placed at the same time as the traveled way, do not take nuclear density readings on the shoulder nor within 1 foot of the shoulder unless the pavement section is uniform across the entire roadway. Mark the outline of the nuclear gauge on the pavement at each location tested with a method of marking that shall last a minimum of 24 hours. Take the nuclear density test at the random location. Do not move the gauge from this location to maximize or minimize the density results. If the Contractor doubts the accuracy of any of the nuclear density test results, the pavement may be cored at the nuclear gauge test locations. If coring is chosen to determine the density for pay adjustment purposes, then all nuclear density test results representing the lot shall be voided and cores taken as prescribed in **subsection 602.6c**.

Take verification nuclear density tests, 1 per subplot, at random locations selected by the Engineer. Payment factors will be based on the Contractor's nuclear density test results, provided those results are validated by KDOT's nuclear density tests.

The Engineer will determine a calibration factor for the Contractor's nuclear density device at the same time as a calibration factor is determined for KDOT's device. The Contractor will be afforded the opportunity to observe the calibration procedure whether it is performed at the district laboratory or on the project site. The Engineer should provide calibration factors by the end of the working day following the date of collecting the cores. In cases where this is not possible, the Contractor and the Engineer may agree in advance to accept a zero pay adjustment for the concerned lots.

The Engineer and Contractor will compare nuclear density test results before any traffic is allowed on the roadway. If the Contractor or KDOT density values are suspect, the Engineer may approve re-testing the locations in question. When re-testing is approved, substitute the new nuclear density values for the values in question. Before traffic is allowed on the roadway, the Contractor needs to determine if cores will be taken.

c. Cores (For mixes with a specified thickness of 1½ inches or greater.) Take 2 cores at random locations within each subplot. It may be necessary to chill the compacted mixture before coring so that the samples may be removed intact without distortion. Cut the samples using a 4-inch coring device, unless a 6-inch coring device is approved by the Engineer. Mark all samples with the lot number, subplot number and core number.

Transport the cores to the laboratory as soon as possible to prevent damage due to improper handling or exposure to heat. Cut all cores including the Engineer's verification cores. The Contractor will be paid only for cores cut to calibrate the nuclear gauge, when requested by the Engineer. Use KT-15 Procedure III to determine core density.

Do not take cores within 1 foot of a longitudinal joint or edge, nor within 20 feet of a transverse joint. For shoulders with a plan width of less than or equal to 3 feet, and placed at the same time as the traveled way, do not

take cores on the shoulder nor within 1 foot of the shoulder unless the pavement section is uniform across the entire roadway.

Take 1 verification core per subplot (at locations selected by the Engineer) for testing at KDOT’s laboratory. Density pay adjustment factors and control of shoulder density are based on the core results, provided those results are validated by the verification cores sent to KDOT’s laboratory.

Dry the core holes, tack the sides and bottom, fill with the same type of material and properly compact it by the next working day.

602.7 WEATHER LIMITATIONS

Do not place HMA on any wet or frozen surface or when weather conditions otherwise prevent the proper handling and finishing of the mixture.

Only place HMA when either the minimum ambient air temperature or the road surface temperature shown in **TABLE 602-13** is met.

TABLE 602-13: MINIMUM HMA PLACEMENT TEMPERATURES							
Paving Course	Thickness (inches)	Air Temperature (°F)			Surface Temperature (°F)		
		HMA	WMA Foam	WMA Chem	HMA	WMA Foam	WMA Chem
Surface	All	50	45	40	55	50	45
Subsurface	<1.5	50	45	40	55	50	45
Subsurface	≥1.5 and < 3	40	35	30	45	40	35
Subsurface	≥ 3	30	30	30	35	32	32

602.8 MIXTURE ACCEPTANCE

a. General. Test each mix designation at each plant for compliance with **TABLE 602-1**. Acceptance will be made on a lot by lot basis contingent upon satisfactory test results. Obtain test samples of the mix designation from the roadway behind the paving operation before compaction. The sampling device and procedures used to obtain the samples must be approved by the Engineer. Use KT-25 for obtaining HMA from the roadway and splitting of the sample. The Contractor’s quality control tests will be used for acceptance provided those results are verified by KDOT.

A load or loads of mixture which, in the opinion of the Engineer, are unacceptable for reasons such as being segregated, aggregate being improperly coated, foaming aggregate or being outside the mixing temperature range may be rejected. Verification samples will be taken by the Engineer at randomly selected locations from behind the paver. Fill all sample locations before compaction.

The V_a test values will also be used to determine V_a pay adjustments according to **subsection 602.9d**. V_a pay adjustments apply to the HMA placed on the traveled way and shoulders (including ramps and acceleration and deceleration lanes).

b. Lot Definition for Mix Production Sampling and Testing. A lot is defined as an isolated quantity of a specified material produced from a single source or operation. Each lot shall normally be represented by 4 contiguous test results. A lot may be represented by test results on samples taken from 1 or more day’s production.

c. Lot Investigation. The Engineer may examine materials represented by individual test results which lie beyond the Contractor’s normal quality control testing variation. The investigation may be based on either Contractor or KDOT test results. The information from additional testing (including testing of in-place HMA) may be used to define unacceptable work according to **SECTION 105**. The Engineer may apply appropriate price reductions or initiate corrective action.

For any test, if a dispute exists between the Engineer and Contractor about the validity of the other’s test results, the KDOT District Materials Laboratory or the MRC will perform referee testing, except for nuclear density dispute resolution and V_a dispute resolution. If the disputed KDOT test results were generated at the District Laboratory, the MRC will perform the referee tests. If the disputed KDOT test result was generated at the MRC, an

independent laboratory agreeable to both parties will be selected. The Laboratory shall be accredited by the AASHTO Accreditation Program in the appropriate testing category.

If referee testing indicates that KDOT test results are correct, the Contractor pays for the additional testing, including referee testing performed at the MRC. This will be paid using the bid item Contract Deduct which will be an item added to the contract.

If the referee testing indicates that Contractor test results are correct, KDOT pays for the additional testing. Pay the independent lab for the testing and submit the paid invoice to KDOT. The Engineer will reimburse the Contractor (based on the invoice price) as Extra Work, **SECTION 104**.

(1) For nuclear density dispute resolution (the statistical comparison fails and the Contractor questions KDOT's results), the following procedure applies:

- Discard pay factors previously established with the nuclear gauge, and use the core results to establish the pay factors.
- With the Engineer present, take 1 core from each of the locations previously tested with the Contractor's nuclear gauge and KDOT's nuclear gauge (normally 15 cores). Mark all cores with the lot number, subplot number and core number.
- Take the cores to the field laboratory and dry to a constant weight before testing. The Contractor and the Engineer, working together, will determine the core densities (KT-15, Procedure III).
- A statistical comparison will be made between Contractor and KDOT core results. If the t-test passes, KDOT will pay for all cores. The Contractor's test results will be used to calculate the density pay factors. If the t-test fails, KDOT will not pay for the cores. KDOT test results will be used to calculate the density pay factors.

(2) For V_a dispute resolution (the statistical comparison fails and the Contractor questions KDOT results), the following procedure applies for the lots in question:

- Determine which lots to dispute. Only dispute the lot produced immediately prior to the lot currently under production and being tested. Notify the Engineer, prior to the completion of all Contractor V_a testing for this lot. (When production is completed for any mix, the last lot may be challenged the day production is completed). When the hot mix plant shuts down for the winter, the Contractor has a maximum of 7 calendar days to dispute the last lot produced prior to winter shut down.
- Discard V_a and V_a pay adjustment factors previously determined within the lots being questioned.
- All saved gyratory compacted V_a quality control and verification samples and back half of samples within the lots in question will be taken by KDOT to the District Materials Laboratory. All back half of samples shall be a minimum of 35 pounds. Failing to obtain enough material removes the right to dispute resolution. Copies of all paperwork, including work sheets, associated with previous V_a calculations for the disputed lots will also be taken to the District Materials Laboratory.

The following retesting will be completed by KDOT:

- Check the samples to be sure they are dry before retesting. Reweigh the original gyratory compacted V_a quality control and verification samples. Determine the G_{mb} at N_{des} revolutions for all saved gyratory plugs. Compare retest results with original test results. Use this information to isolate potential testing errors, but continue with the remainder of the retesting steps.
- Determine the G_{mm} using the back half of all samples within each lot being questioned. Normally, there will be 5 back halves (4 Contractor's and 1 KDOT) to test within each lot.
- Compact the back halves to N_{max} revolutions and determine the G_{mb} at N_{des} revolutions.
- Use G_{mm} determined above and the G_{mb} determined from the recompacted samples to calculate V_a at N_{des} revolutions for the lots in question.
- Using the retest V_a results, a statistical comparison will be made. If the t-test passes, the Contractor's retest results will be used to calculate the pay factor and KDOT will pay for all retesting. Use the procedures shown in **subsection 602.9d**. If the t-test fails, KDOT's retest results will be used to calculate the pay factor, and the Contractor will pay for all retesting.

d. Resampling of Lots. Take no samples for retest for pay adjustment purposes except as noted in **subsections 602.6b.** and **602.8c.**

e. Multiple Projects. If multiple projects are supplied from 1 or more plants using the same mix, carry over the lots at each hot mix plant from project to project.

f. Lot Size. A standard size mix production lot (density test lots are defined in **subsection 602.6a.(5)**) consists of 4 equal sublots of 750 tons each of HMA (lot size is 3,000 tons).

It is anticipated that lot size shall be as specified. However, with the Engineer’s approval, the Contractor may re-define lot size for reasons such as, but not limited to, change in contract quantities or interruption of the work. Take 1 sample during production of each subplot and utilize it to determine disposition of the lot in which it occurs.

g. Increased Lot Size. After 8 consecutive sublots have been produced within the tolerance shown for all mix characteristics listed in **TABLE 602-12** and without a V_a penalty, the subplot size may be increased to 1,000 tons (lot size of 4,000 tons), provided the normal production rate of the plant is greater than 250 tons per hour. Provide immediate notification of lot size changes to the Engineer any time a change is made.

After 8 additional consecutive sublots have been produced at the 1,000 ton subplot size, the subplot size may again be increased to 1,250 tons per subplot (lot size of 5,000 tons), provided all 8 consecutive 1,000 ton sublots have been produced within the tolerances shown for all mix characteristics listed in **TABLE 602-12**, without a V_a penalty, production rates for the previous 2 days have been greater than 3,750 tons per day, and a minimum of 2 of the last 3 segregation profile checks comply with **TABLE 602-14**.

TABLE 602-14: SEGREGATION PROFILE CHECKS FOR INCREASED SUBLOT SIZE		
Mix Designation	Maximum Density Range (highest minus lowest)	Maximum Density Drop (average minus lowest)
All	3.1 lbs./cu. ft.	1.9 lbs./cu. ft.

If subsequent test results fall outside the tolerances shown for any mix characteristic listed in **TABLE 602-12** or a V_a penalty is incurred, decrease the subplot size to 750 tons. If the production rates fall below 3,750 tons per day for 2 consecutive days or a minimum of 2 of the last 3 segregation profile checks fail the above requirements, then reduce the 1,250 ton sublots size to 1,000 ton per subplot provided the **TABLE 602-12** criteria is met and no V_a penalty is incurred.

When the increased lot size criteria are again met for 4 consecutive sublots, the subplot may be increased as the limits given above.

h. Decreased Lot Size for Small Quantities. This is to be used when a small quantity (less than 3,000 tons) of a particular mix will be used. Use the plan quantity for the lot size. Reduce the subplot size below 750 tons by dividing the lot into 3 or 4 equal sublots. Before beginning production, provide the Engineer with the number and size of the sublots.

i. Pre-Production Mix. Test and evaluate a pre-production mix, limited to a maximum of 200 tons from each plant and type of mix before production of that mix. Evaluate the pre-production mix at initial start-up and after suspension of production resulting from failing test results. Do not adjust V_a payment for pre-production mixes. Provide a pre-production mix that complies with the gradation, D/B ratio, binder content, VMA, level of compaction for N_{ini} , N_{des} , N_{max} and laboratory V_a requirements prior to starting or resuming production. For binder content, V_a at N_{des} and VMA, use the "Single Test Value" listed in **TABLE 602-12** for comparison. For the other tests listed, use the values listed in **TABLE 602-1** for each mix. Except for initial start-up, normal delivery of material to the project before completion of certain test results on pre-production mixes may be authorized by the DME.

Place the material produced for the pre-production mix in locations approved by the DME. On projects where HMA is paid by the ton, consider placing the pre-production mix in non-critical areas such as side roads, entrances, shoulders or deep in the base. The Engineer will pay for material as the material produced, not in the location placed. However to prevent potential cost overruns, do not run an excessive number of “higher cost” pre-production mixes (as determined by the Engineer) on shoulders or entrances.

On projects in which the HMA is paid by the square yard, place pre-production mixes where required by the Contract Documents. A higher quality pre-production mix may be placed at no additional expense to KDOT. If HMA materials which are designated to be placed in the top 4 inches of the pavement structure are placed deeper

than 4 inches as a pre-production mix, do not count the material toward the requirement to place the material in the top 4 inches of the pavement section.

At the direction of the Engineer, remove the pre-production mix if it is both out of specification and the material shortens the pavement life or changes the intended function. The Engineer will pay for the replacement of one pre-production mix at 100% of the contract unit price for each mix in the contract (not each mix design). If the HMA is paid by the square yard, then the removed material will be paid for at a rate of \$40 per ton. The Engineer will create a change order (**SECTION 104**) adding the item of work with a unit price of \$40/ton. The payment will be full compensation to the Contractor for the placement and removal of that pre-production mix. KDOT will not be financially responsible for any subsequent failed pre-production mixes (that require removal) for that mix. The removed material is the property of the Contractor.

The Engineer will not pay for pre-production mixes that are required to be replaced due to poor workmanship or equipment failure. The Engineer will make the final decision to remove a failed pre-production mix with input from the Contractor.

j. Suspension of Mix Production. Suspend production of the mix until appropriate corrections have been made, if 2 consecutive test results for any single mix characteristic fail to fall within the limits established by the tolerances shown in the single test value column of **TABLE 602-12**. Additionally, suspend production of the mix until appropriate corrections have been made, if any 4-point moving average value for any single mix characteristic fails to fall within the limits established by the tolerances shown in the 4-point moving average value column of **TABLE 602-12**. Production remains suspended pending the satisfactory results of a pre-production mix, unless waived by the DME.

The Engineer may stop production of HMA at any time the mix or process is determined to be unsatisfactory. Make the necessary corrections before production will be allowed to resume. Failure to stop production of HMA subjects all subsequent material to rejection by the Engineer, or acceptance at a reduced price, as determined by the Engineer.

602.9 BASIS OF ACCEPTANCE

a. General. Acceptance of the mixture will be contingent upon test results from both the Contractor and KDOT. The Engineer will routinely compare the variances (F-test) and the means (t-test) of the verification test results with the quality control test results for V_a , G_{mm} and density using a spreadsheet provided by KDOT. If KDOT verification test results do not show favorable comparison with the Contractor's quality control test results, then KDOT test results will be used for material acceptance, material rejection and the determination of any pay adjustment on the V_a and roadway density. Disputed test results will be handled according to **subsection 602.8c**.

KDOT will use a spreadsheet program to calculate pay adjustments for density and V_a , and to compare Contractor QC and KDOT QA test results (including G_{mm}). KDOT will provide a copy of this program to the Contractor, when requested. Microsoft Excel software is required to run this program; it is the Contractor's responsibility to obtain the correct software. Values computed using equations referenced in this specification may vary slightly from the spreadsheet values due to rounding of numbers. In such cases, the numbers computed by the spreadsheet will govern.

The comparison of quality control and verification tests will be completed using the t-tests to compare their population means and the F-test to compare their variances. The F & t tests, along with the Excel Spreadsheet used to compare the Contractor's QC results and KDOT's QA results, are described in Section 5.2.6 – Comparison of Quality Control and Verification Tests, Part V. (Examples of Air Voids F & t tests, along with Density F & t tests are shown in this section.) Additional information on the program may be obtained from the Bureau of Construction and Materials.

b. Asphalt Density Pay Adjustment for "HMA Overlay" Bid Items. Mixes with specified thickness of less than 1½ inches are not subject to the asphalt density pay adjustments.

For mixes with specified thickness of 1½ inches or greater: Asphalt density pay adjustment for compaction of the completed pavement shall be by lot, based on the percentage of G_{mm} obtained. Compute the asphalt density pay adjustment (incentive or disincentive) by multiplying the density pay adjustment factor (P_D) times the number of tons included in the lot times \$40 per ton. (Air voids lots and density lots are normally of different sizes.) This adjustment will be paid for under the bid item Asphalt Density Pay Adjustment.

Density pay factors will be determined from **TABLE 602-15**. (For **TABLE 602-15**, average the percent of G_{mm} values to 0.01% and calculate the density pay adjustment factors rounded to the thousandths).

TABLE 602-15: DENSITY PAY FACTORS FOR SPECIFIED THICKNESS ⁴		
Specified Thickness →	≥ 2"	≥ 1½"
	All	Continuous Action ⁵
% of G _{mm} Average of 10 Density Tests ¹	Pay Factor ²	Pay Factor ²
93.00% or greater	1.040	1.040
92.00 to 92.99%	A1	A1
91.00 to 91.99%	1.000	1.000
90.00 to 90.99%	A2	1.000
89.00 to 89.99%	0.840 or Remove ³	A3
less than 89.00%	0.840 or Remove ³	0.840 or Remove ³

¹For low daily production rates less than 1000 tons, or when the Engineer's verification tests are to be used for asphalt density pay determination, the lot sample size is as determined in TABLE 602-10.

²Shoulders: For shoulders with a plan width greater than 3 feet and any shoulder not placed at the same time as the traveled way, compact the HMA in the lot to a minimum of 90.00% (if specified thickness is ≥2") or 89.00% (if the specified thickness is from 1½" to 1⅞") of the G_{mm}. Otherwise, the Engineer will determine whether the HMA in the lot may remain in place or be removed. Any such material left in place shall have a density pay factor of 0.950 or less.

³Low Density: The Engineer will determine if the traveled way, shoulders with a plan width of 3 feet or less and placed with the traveled way, ramps, acceleration and deceleration lanes may remain in place or be removed. The Engineer will notify the Contractor before 11:00 AM of the next working day if the area is to be removed. Any such material left in place shall have a density pay factor of 0.840.

⁴Specified thickness is the total thickness shown in the Contract Documents for the mix being placed.

⁵Use for ≥1½" when another continuous action, such as milling, surface recycling, cold recycling or overlay is completed ahead of this overlay.

⁶Use for ≥1½" when another continuous action is not completed before the overlay.

Calculations for Density Pay Factors A1, A2 and A3:

$$A1 = [100 + 4 (\% \text{ of lot } G_{mm} - 92.00)] \div 100$$

$$A2 = [84 + 16 (\% \text{ of lot } G_{mm} - 90.00)] \div 100$$

$$A3 = [84 + 16 (\% \text{ of lot } G_{mm} - 89.00)] \div 100$$

Density Pay Adjustment Factor Calculation:

$$\text{Density Pay Adjustment Factor } (P_D)^* = \text{Density Pay Factor} - 1.000$$

*P_D rounded to the nearest thousandth

c. Asphalt Density Pay Adjustment for "HMA Surface", "HMA Base" and "HMA Pavement" Bid Items. Asphalt Density Pay Adjustment for compaction of the completed pavement shall be by lot, based on the percentage of G_{mm} obtained. This adjustment will be paid for under the bid item Asphalt Density Pay Adjustment. Compute the Asphalt Density Pay Adjustment (positive or negative) by multiplying the Density Pay Adjustment factor (P_D) times the number of tons included in the lot times \$40 per ton. The Asphalt Density Pay Adjustment will be added or subtracted on the pay estimate. For shoulders with a plan width of less than or equal to 3 feet, and placed at the same time as the traveled way, the P_D for the traveled way will apply. The P_D does not apply to sideroads, entrances, crossovers and other incidental surfacing. Use KDOT test results for the lot to determine the P_D when the statistical comparison between the quality control and the verification tests fail (see subsection 602.9a.).

Lot Size: A lot shall normally be comprised of the results of 10 tests performed on a day's placement of a given mix placed in a given lift. Lot size is defined in subsection 602.6. (Air void lots and density lots are normally of different sizes).

Shoulders: For all shoulders with a plan width greater than 3 feet and any shoulder not placed at the same time as the traveled way, the lower specification limit (LSL) is 90.00%. When the lower percent within limits (PWL_{LD}) is 50.00% or more for the lot, P_D is zero. When the PWL_{LD} is less than 50.00% for the lot, the Engineer will determine whether the HMA in the lot may remain in place or be removed. Any such material left in place will have a P_D of -0.050, unless the Engineer establishes lower values for P_D (-0.100, -0.200, -0.300, etc.) as a condition of leaving the material in place.

Determination of P_D and $PWLLD$: Calculate the lower density quality index (Q_{LD}) for each lot using Equation 1 and round to hundredths. Locate the Q_{LD} value in the left column of the Percent Within Limits (PWL) Table in Section 5.2.1 - Statistics, Part V. Select the appropriate $PWLLD$ value by moving across the selected quality index row to the column representing the number of samples in the lot.

If Q_{LD} is greater than the largest quality index value shown in the table, use 100.00 as the value for $PWLLD$.

If $PWLLD$ is less than 50.00% for the lot, the Engineer will determine if the material in the lot may remain in place. If the material is left in place, the value of P_D for the lot will be equal to -0.160, unless the Engineer establishes lower values for P_D (-0.200, -0.300, etc.) as a condition of leaving the material in place. Otherwise, calculate P_D using Equation 2 and round to thousandths.

Equation 1:
$$Q_{LD} = \frac{\bar{X} - LSL}{S}$$

\bar{X} is the average measured percent of G_{mm} of all samples within a lot rounded to hundredths.

LSL is the lower specification limit for density and is defined as 91.00% of G_{mm} for traveled way plan thickness 2 inches and less and 92.00% of G_{mm} for traveled way plan thickness greater than 2 inches.

S is the standard deviation of the measured density of all samples within a lot and is calculated using equation (4) in Section 5.17.09, Part V, rounded to hundredths.

Equation 2:
$$P_D = (PWLLD * 0.004) - 0.360$$

d. Asphalt Air Void Pay Adjustment. Asphalt Air Void (V_a) Pay Adjustment will be made on a lot basis and based on measured V_a from samples of plant produced material. This adjustment will be paid for under the bid item Asphalt Air Void Pay Adjustment. The V_a pay adjustment factor (P_V) (positive or negative) will be determined and used to compute the V_a Pay Adjustment by multiplying P_V times the number of tons included in the lot times \$40 per ton. The V_a Pay Adjustment will be added or subtracted on the pay estimate. When the statistical comparison between the quality control and the verification tests pass, use the procedures in **subsection 602.9d.(1)** to compute P_V . When the statistical comparison fails, calculate P_V using procedures in **subsection 602.9d.(2)**.

Lot Size: A lot shall normally be comprised of the results of 4 contiguous individual V_a tests performed on gyratory compacted samples of a given mix design. Lot size is defined in **subsections 602.8f, 602.8g, and 602.8h**. When there are 1 or 2 tests remaining, such as at the end of a project or season, combine them with the previous 4 tests to create a 5 or 6 test lot, respectively. When there are 3 tests remaining, combine the 3 tests into a lot. (Air voids lots and density lots are normally of different sizes).

(1) Air Voids Pay Adjustment Factor (Passing t-test). Calculate the upper and lower V_a quality indices (Q_{UV} and Q_{LV}) for each lot using Equations 3 and 4, respectively and round to hundredths. Locate the Q_{UV} value in the left column of the Percent Within Limits (PWL) Table in Section 5.2.1 – Statistics, Part V. Select the appropriate upper percent within limit value ($PWLUV$) by moving across the selected quality index row to the column representing the number of samples (N) in the lot. Repeat the process using the Q_{LV} value and select the appropriate value for the lower percent within limits ($PWLLV$). If the Q_{UV} or Q_{LV} value is greater than the largest quality index value shown in the table, then a value of 100.00 is assigned as the value for $PWLUV$ or $PWLLV$, respectively. If both Q_{UV} and Q_{LV} exceed the values shown in the table, a value of 100.00 is assigned as the value for both $PWLUV$ and $PWLLV$. If either Q_{UV} or Q_{LV} is a negative value or $PWLUV + PWLLV$ is less than 150.00, the Engineer will determine if the material in the lot may remain in place. If the Engineer determines that the material may remain in place then the maximum value of P_V for the lot will be equal to -0.120. The Engineer may establish lower values for P_V (-0.200, -0.300, etc.) in such instances. Otherwise, calculate P_V using Equation 5 and round to thousandths.

Equation 3:
$$Q_{UV} = \frac{USL - \bar{X}}{S}$$

Equation 4:
$$Q_{LV} = \frac{\bar{X} - LSL}{S}$$

\bar{X} is the average measured V_a of all samples within a lot rounded to hundredths.

USL is the upper specification limit for V_a and is defined as 5.00%.

LSL is the lower specification limit for V_a and is defined as 3.00%.

S is the standard deviation of the measured V_a for all samples within a lot and is calculated using equation (4) in Section 5.2.1 - Statistics, Part V, rounded to hundredths.

Equation 5:
$$P_V = ((PWL_{UV} + PWL_{LV} - 100.00)(0.003)) - 0.270$$

PWL_{UV} is the upper percent within limits value for V_a .

PWL_{LV} is the lower percent within limits value for V_a .

(2) Air Voids Pay Adjustment (Failing t-Test). If the t-test fails, KDOT's test result will be used to calculate the P_V for the lot. Follow the procedures given in **subsection 602.9d.(1)** to determine the P_V or disposition of the lot. Use the values from **TABLE 602-16** to calculate Q_{UV} , Q_{LV} , PWL_{UV} and PWL_{LV} in Equations 3, 4 and 5 in **subsection 602.9d.(1)**.

TABLE 602-16: Statistical Values for Air Voids Pay Adjustment for Failing t-Test		
Term	Definition	Value
\bar{X}	Average or Mean	KDOT's test result for the lot
S	Standard Deviation	0.50
USL	Upper Specification Limit	5.50%
LSL	Lower Specification Limit	2.50%
N	Sample Size	3

602.10 DETERMINATION OF THICKNESS, THICKNESS PAY ADJUSTMENT AND AREA PAY ADJUSTMENTS FOR "HMA PAVEMENT" AND "HMA PAVEMENT SHOULDER" BID ITEMS

a. General. Construct the pavement to the dimensions shown in the Contract Documents. Inform the Engineer when a section is ready for coring and measurement of width and length. Complete all paving of the shoulder and driving lanes within this section, unless otherwise approved by the Engineer.

A driving lane is defined as mainline lanes, acceleration lanes (including tapers), deceleration lanes (including tapers), auxiliary lanes, ramp lanes or combination thereof.

When shoulders, medians and widenings are placed monolithically with the adjacent driving lane, and there is not a separate bid item for shoulders, then the shoulders are considered as part of the driving lane, and are subjected to the same unit price adjustment as the driving lane.

b. Measurements. The Engineer will divide the projects into lots. A lot is comprised of 5 sublots with the same plan thickness. A subplot is defined as a single driving lane or a single shoulder, with an accumulative length of 1000 feet. If the last lot has 1 or 2 sublots (such as at the end of a project or season), combine them with the previous lot to create a lot with 6 or 7 sublots, respectively. Consider as a single lot if there are 3 or 4 sublots in the final lot.

The Engineer will generate 1 random location for coring within each subplot. Do not take a core within 1 foot of a longitudinal joint or edge. Obtain the cores with the Engineer present.

Take a 4-inch diameter core from the selected sites. Mark each core with its lot and subplot number, and transport to the KDOT field lab.

For information only, the Engineer will determine the thickness of each HMA mixture and the total HMA base for each core.

The Engineer will determine the total core thickness for pay by taking 3 caliper measurements at approximately 120° apart and record each to the nearest 0.1 inch. The average of the 3 caliper measurements rounded to the nearest 0.1 inch shall represent the average measured thickness. The Engineer will use the total pavement thickness measurements to determine thickness pay adjustment factors.

The Engineer will provide a copy of the results to the Contractor before the end of the following working day.

Prior to coring, the Contractor may request that areas trimmed without automatically controlled equipment be handled separately. (This would require the Contractor to designate the area as a lot before knowing the actual core thickness.) When requested and approved by the Engineer, each area will be considered a lot. Divide the area into 5 sublots and obtain 1 core from each subplot.

For Percent Within Limits (PWL) thickness analysis, if any subplot thickness exceeds the design thickness by more than 1.0 inch, the Excel spreadsheet will automatically consider that subplot thickness to be 1.0 inch more

than the design thickness. The spreadsheet will recalculate a new lot mean and sample standard deviation based on the adjusted value.

Dry the core holes, tack the sides and bottom, fill them with a HMA mixture (approved for the project) and properly compact it by the end of the next working day.

c. Deficient Measurements for Driving Lanes. When any full depth core for driving lanes is deficient by 1.0 inch or greater from the specified thickness, take exploratory cores at intervals a minimum of 50 feet in each direction (parallel to the centerline) from the deficient core.

Continue to take exploratory cores in each direction until a core is taken that is deficient a maximum of 0.5 inch. Exploratory cores are used only to determine the length of pavement in a lot that is to be overlaid, as approved by the Engineer.

The minimum overlay length (with surface mix) shall be equal to the distance between the cores that are deficient by a maximum of 0.5 inch, and the width to be paved shall be full width of the roadway (driving lanes and shoulders) when this occurs.

The minimum overlay thickness is 3 times the nominal maximum aggregate size.

Complete the overlay to the satisfaction of the Engineer. Mill butt joints on the ends of the overlay area. The Engineer will not pay for any milling costs.

The exploratory cores are not used to determine thickness pay adjustment factors. Randomly select another core (outside the overlay area) to represent the subplot.

d. Deficient Measurements for Shoulders. When any full depth core taken from the shoulders is deficient by greater than 1.5 inches, take exploratory cores at intervals a minimum of 50 feet in each direction (parallel to the centerline) from the deficient core.

Continue to take exploratory cores in each direction until a core is only deficient a maximum of 0.8 inches.

Exploratory cores are used only to determine the length of pavement in a lot that is to be removed and replaced, or accepted at a reduced price (in addition to any disincentive assessed on that lot), as approved by the Engineer.

The minimum repair length is equal to the distance between the cores that are deficient a maximum of 0.8 inches, and the full width of the shoulder.

Mill butt joints on the ends of the overlay area. The Engineer will not pay for any milling costs. Unless approved by the Engineer, replacing includes complete removal of all HMA within the area defined by the results of the exploratory cores. Rework, stabilize (if required) and regrade the subgrade. When required, reconstruct the base and replace all HMA mixes shown in the Contract Documents. Obtain 1 random core within this subplot and use its core length to determine the thickness pay adjustment factor.

e. Asphalt Pavement Area Pay Adjustment. Determine the areas for pay and pay adjustment as shown in **TABLE 602-18**. The KDOT spreadsheet program will calculate these areas. This adjustment will be paid for under the bid item Asphalt Pavement Area Pay Adjustment.

Irregularly shaped areas may have to be calculated outside the program and the area entered into the program. Compute pay per lot for areas placed and not placed (deducted) as shown in Equations 10, 11, 12 and 13.

Equation 10: Pay for Driving Lane = $(\sum PDLA)(BP)$

Equation 11: Pay Deduct for Driving Lanes = $2(\sum PDLDA)(BP)$

Equation 12: Pay for Shoulder = $(\sum PSA)(BP)$

Equation 13: Pay Deduct for Shoulder = $2(\sum PSDA)(BP)$

$\sum PDLA$ = Pay Driving Lane Area per Lot, Square Yard

$\sum PDLDA$ = Pay Driving Lane Deduct Area per Lot, Square Yard

$\sum PSA$ = Pay Shoulder Area per Lot, Square Yard

$\sum PSDA$ = Pay Shoulder Deduct Area per Lot, Square Yard

BP = Bid Price for either the driving lanes or the shoulder, as applicable

TABLE 602-17: HMA AREA ABBREVIATIONS			
Abbreviation		Definition	Units
PDLA	=	Pay Driving Lane Area per Sublot	Sq Yd
PDLDA	=	Pay Driving Lane Deduct Area per Sublot,	Sq Yd
PSA	=	Pay Shoulder Area per Sublot	Sq Yd
PSDA	=	Pay Shoulder Deduct Area per Sublot	Sq Yd
MDLW	=	Measured Driving Lane Width	Ft
MSW	=	Measured Shoulder Width	Ft
MTLW	=	Measured Total Lane Width (includes shoulder, if any)	Ft
PDLW	=	Plan Driving Lane Width	Ft
PSW	=	Plan Shoulder Width	Ft
PTLW	=	Plan Total Lane Width (includes shoulder, if any)	Ft
EDLW	=	Excess Driving Lane Width	Ft
SL	=	Sublot Length	Ft

TABLE 602-18: HMA AREA SUBLOT CALCULATIONS ¹				
Condition	PDLA ² (Sq Yd)	PDLDA ² (Sq Yd)	PSA ² (Sq Yd)	PSDA ² (Sq Yd)
Projects with a Separate Bid Item for Shoulder				
Narrow Driving Lane				
MSW is less than PSW	(SL)(MDLW)	(SL)(PDLW-MDLW)	(SL)(MSW)	(SL)(PSW-MSW)
MSW is greater than PSW	(SL)(MDLW)	(SL)(PDLW-MDLW)	(SL)(MSW ³)	0
Wide Driving Lane				
MSW + EDLW is less than PSW	(SL)(PDLW)	0	(SL)(MSW+EDLW)	(SL)(PSW-MSW-EDLW)
MSW + EDLW is greater than PSW	(SL)(PDLW)	0	(SL)(MSW+EDLW ⁴)	0
Projects without a Separate Bid Item for Shoulder⁵				
Narrow Driving Lane and Shoulder	(SL)(MTLW)	(SL)(PTLW-MTLW)	N/A	N/A
Wide Driving Lane and Shoulder	(SL)(MTLW ⁶)	0	N/A	N/A

¹Deductions will be made for unplaced areas.

²Calculate the areas to the nearest 0.01 square yards. Measure the lengths and widths to the nearest 0.01 feet. Divide the result of all equations in this table by 9 so that the resulting units are square yards.

³MSW shall be between PSW and PSW + 0.25 feet. Any excess width over 0.25 feet will not be included in PSW.

⁴MSW+ EDLW shall be between PSW and PSW + 0.25 feet. Any excess width over 0.25 feet will not be included in PSW.

⁵Shoulder is normally 0.00 feet to 3.00 feet wide and placed at the same time as the driving lane. PTLW = PDLW + PSW

⁶MSTLW shall be between PTLW and PTLW + 0.25 feet. Any excess width over 0.25 feet will not be included for pay.

f. Asphalt Pavement Thickness Pay Adjustment. Compute the Asphalt Thickness Pay Adjustment for the driving lanes (TPA_{DL}) and shoulders (TPA_{SH}) using Equation 6 or 7, respectively. Compute the Asphalt Thickness Pay Adjustment factor (P_T) as shown in Equation 9. Determine area calculations for the driving lanes and shoulders as shown in TABLE 602-18. TABLE 602-17 provides the definition for the abbreviations used in TABLE 602-18. Enter the measured values into the spreadsheet program to determine PDLA and PSA.

This adjustment will be paid for under the bid item Asphalt Pavement Thickness Adjustment.

Equation 6: $TPA_{DL} = P_T (\sum PDLA) (\$1.90) (\text{Plan Thickness})$

Equation 7: $TPA_{SH} = P_T (\sum PSA) (\$1.70) (\text{Plan Thickness})$

TPA_{DL} = Thickness Pay Adjustment per Lot for Driving Lane

TPA_{SH} = Thickness Pay Adjustment per Lot for Shoulder

∑PDLA = Pay Driving Lane Area per Lot, Square Yard

Σ PSA = Pay Shoulder Area per Lot, Square Yard
 Plan Thickness = HMA Thickness shown on Plans, Inches

KDOT will use a spreadsheet program to calculate thickness pay adjustments. KDOT will provide a copy of this program to the Contractor, when requested. It is the Contractor's responsibility to obtain the Microsoft Excel software required to run this program. Values computed using equations referenced in this specification may vary slightly from the spreadsheet values due to rounding of numbers. In such cases the numbers computed by the spreadsheet take precedence.

Thickness Quality Index (Q_T) Computation. In each lot, calculate Q_T for the total pavement thickness using Equation 8 and round to hundredths.

Equation 8:
$$Q_T = \frac{\bar{X} - LSL}{S}$$

\bar{X} = Average total core length of all samples representing a lot, rounded to the nearest 0.1 inch. (Adjust core length before averaging, as shown in **subsection 602.10b.**)

LSL = Lower specification limit for thickness. For driving lanes use 0.5 inch less than the total plan driving lane thickness shown on the typical section. For shoulders, use 0.8 inch less than the total plan shoulder thickness shown on the typical section.

S = Sample standard deviation of the measured core lengths of all samples representing a lot and is calculated using equation (4) in Section 5.2.1 – Statistics, Part V, rounded to hundredths.

Use the computed Q_T to determine the thickness Percent Within Limits value (PWL_T) by locating the Q_T in the left column of the Percent Within Limits (PWL) Table in Section 5.2.1 - Statistics, Part V. Select the appropriate PWL_T by moving across the selected Q_T row to the column representing the number of samples in the lot.

If the computed Q_T is a negative value, then the lot and all adjacent areas (full width of roadway) shall be overlaid as determined by the Engineer. After the lot has been overlaid, randomly select another core for each subplot, and calculate a new pay factor. For lots that have been entirely overlaid, the maximum pay factor is zero.

If the computed Q_T is greater than the largest Q_T shown in the PWL Table, a value of 100.00 is assigned as the PWL_T for thickness.

For each lot and all lanes and shoulders, compute the thickness pay factor (P_T) for the total pavement thickness using Equation 9 and round to nearest thousandth. No bonus will be paid for shoulders, thus use $P_T = 0.000$ whenever P_T calculates greater than 0.000 for shoulders.

Equation 9:

$$P_T = \left(\frac{(PWL_T) * 0.3}{100} \right) - 0.270$$

g. Minimum Quantity of HMA for Square Yard Projects with "HMA Pavement" and HMA Pavement Shoulder" Bid Items. For the total project, supply a minimum of 93% of G_{mm} required by the surface course of driving lanes and shoulders and the top base course of driving lanes and shoulder. Calculate the minimum quantity of those 2 mixes, individually as follows:

Equation 14:
$$\text{Minimum Quantity (Tons)} = \frac{0.93 (A) (T) (G_{mm})}{42.7}$$

A = Area in square yards for each of the mixes.

T = Plan thickness in inches of surface course and the top base course of driving lanes and shoulders.

G_{mm} = Theoretical maximum specific gravity equals the average G_{mm} value used in the first 5 lots or the average G_{mm} for 1/2 of the project (whichever is less) for the 4 mixes listed in "T" in Equation 14. Determine the average G_{mm} from the Excel worksheet titled "Density F & T Test Worksheet".

If this minimum quantity of surface course or base course is not placed, a deduction of \$40 per ton will apply to the quantity not placed for each mix. This will be paid using the bid item Contract Deduct which will be an item added to the contract.

602.11 MEASUREMENT AND PAYMENT

a. "HMA Base", "HMA Surface" and "HMA Overlay" Bid Items. The Engineer will measure HMA Base, HMA Surface and HMA Overlay by the ton of material at the time of delivery to the road. Batch weights will not be allowed as a method of measurement unless all the following conditions are met:

- the plant is equipped with an automatic printer system approved by the Engineer;
- the automatic printer system prints the weights of material delivered; and
- the automatic printer system is used in conjunction with an automatic batching and mixing control system approved by the Engineer.

Provide a weigh ticket for each load. Due to possible variations in the specific gravity or weight per cubic foot of the aggregates, the tonnage used may vary from the proposal quantities and no adjustment in contract unit price will be made because of such variances.

Payment for "HMA Base (*)(**)(***)", "HMA Surface (*)(**)(***)" and "HMA Overlay (*)(**)(***)" at the contract unit prices is full compensation for the specified work. Any pay adjustments will both be applied and the payment adjusted accordingly.

Sideroads, entrances and mailbox turnouts that are not shown in the Contract Documents that are to be surfaced shall be paid for at 1½ times the unit price for "HMA Surface (*)(**)(***)" or "HMA Base(*)(**)(***)".

b. "HMA Pavement" and "HMA Shoulder" Bid Items. The Engineer will measure HMA Pavement and HMA Pavement Shoulder by the square yard of the measured in-place material. All lifts, except the surface course, will be measured by the Contractor and verified by the Engineer. The Engineer will measure the surface course.

Measure each shoulder width, each driving lane width and subplot length separately. Measure the lengths (to the nearest 0.01 feet) a minimum of once per subplot. The location of the width measurements will be the same location as the mainline cores which were established using random numbers. Before the end of the next working day, type and submit to the Engineer, the Contractor's individual measurements and the sum of the 2 driving lanes. Likewise, when the surface course is completed the Engineer will provide a typed copy of the surface course measurements to the Contractor before the end of the next working day.

If the driving lane and shoulder (measured from centerline) is less than 0.25 feet (per side) deficient, a deduction will be assessed. If the roadway is greater than 0.25 feet (per side) deficient, correction will be required. The correction will be proposed by the Contractor and must be approved by the Engineer. After satisfactory correction by the Contractor, the deduction for the narrow roadway will be eliminated for the areas corrected.

The Engineer will measure the subplot length and width (to the nearest 0.01 feet). Measure the width from the construction joint to the top of the slope of HMA pavement. Calculate the pay area for each lot to the nearest square yard. Unless the Engineer authorizes in writing to increase the area of HMA pavement, the Engineer will use dimensions shown in the Contract Documents and as measured in the field to calculate the final pay quantity. If the Engineer authorizes in writing to increase the area of HMA pavement or shoulder, the additional area will be measured and paid for as "HMA Pavement (#) (##)" or "HMA Pavement (#) Shoulder", respectively. The length will be measured horizontally along the centerline of each roadway or ramp.

Payment for "HMA Pavement (#) (##)" and "HMA Pavement (#) Shoulder" at the contract unit prices is full compensation for the specified work.

The Asphalt Pavement Thickness Adjustment and Asphalt Pavement Area Pay Adjustment will be entered on the Contractor's Payment Vouchers (intermediates and final) after each lot of the surface course (driving lanes and shoulders) has been completed.

The Contractor will receive no additional compensation for overlaying or for removing and replacing areas of deficient thickness. Exploratory cores and cores taken to determine pavement thickness will not be measured for payment. The Engineer will apply a Contract Deduct for surface course (driving lanes and shoulders) and top base course (driving lanes and shoulders) mix not placed on the project as determined using Equation 14. The Contract Deduct will be computed by the spreadsheet and be an item added to the contract.

If the project has a large amount of grinding required for pavement smoothness, the Engineer may require the Contractor to cut cores after the grinding is complete. These cores will be used in the spreadsheet in place of the cores originally cut.

c. Emulsified Asphalt. The Engineer will measure emulsified asphalt used for tack by the ton. Payment for "Emulsified Asphalt" at the contract unit price is full compensation for the specified work.

d. Asphalt Core (Set Price).

(1) Nuclear Density Gauge Calibration. The Engineer will measure each asphalt core required by the Engineer to calibrate the nuclear density gauges. No payment will be made for cores deemed unsuitable for calibrating the nuclear density gauges. No payment will be made for cores taken at the Contractor's option to determine density.

(2) Nuclear Density Dispute Resolution. If during nuclear density dispute resolution, the Contractor's test results are used for payment, the Engineer will measure each core taken for payment at the Asphalt Core (Set Price). If KDOT's test results are used for payment, then no payment for cores will be made for nuclear density dispute resolution.

(3) Payment for "Asphalt Core (Set Price)" at the contract set unit price is full compensation for the specified work.

e. Material for HMA Patching (Set Price). When the Contractor is required to remove any existing base course, subgrade or surface course (unless damaged by the Contractor) and provisions are not made in the Contract Documents, the Engineer will measure the material used for repair and patching (either HMA-Commercial Grade or a specified mix on the project) separately, by the ton at the time of delivery to the road. The Engineer will not measure the quantity of material used in the repair of damage due to the Contractor's negligence. The Engineer will measure HMA materials by the ton. For mixes containing Reclaimed HMA Pavement (RAP) or Recycled Asphalt Shingles (RAS), compute the HMA material contained in the RAP and RAS using the binder content determined from ignition oven testing. Maintain this information for materials tracking purposes. No separate payment for HMA material in RAP and RAS will be made. Combined gradation results will be used for acceptance in accordance with **TABLE 602-1**.

Payment for "Material for HMA Patching (Set Price)" at the contract set unit price includes all excavation, compaction of subgrade or subbase if required, disposal of waste material and all material (including emulsified asphalt for tack), all labor, equipment, tools, supplies, incidentals and mobilization necessary to complete the work. Pay adjustments will not be applied to this material.

f. Quality Control Testing (HMA). The Engineer will measure Quality Control Testing (HMA) performed by the Contractor on a per ton basis of HMA Surface, HMA Base, HMA Overlay and HMA Pavement placed on the project. No adjustment in the bid price will be made for overruns or underruns in the contract quantity. The bid price will constitute payment for all necessary mix design testing, field process control testing, the testing laboratory and all necessary test equipment.

The Engineer will not measure for payment Quality Control Testing (HMA) for the bid item Material for HMA Patching (Set Price).

Payment for "Quality Control Testing (HMA)" at the contract unit price is full compensation for the specified work.

07-27-18 C&M (BTH)
Sept-18 Letting

**KANSAS DEPARTMENT OF TRANSPORTATION
 SPECIAL PROVISION TO THE
 STANDARD SPECIFICATIONS, 2015 EDITION**

Delete SECTION 1102, and replace with the following:

SECTION 1102

AGGREGATES FOR CONCRETE NOT PLACED ON GRADE

1102.1 DESCRIPTION

This specification is for coarse aggregates, intermediate aggregates, fine aggregates, mixed aggregates (coarse, intermediate and fine material) and miscellaneous aggregates for use in construction of concrete not placed on grade.

For Intermediate Aggregates and Mixed Aggregates, consider any aggregate with 30% or more retained on the No. 8 sieve to be Coarse Aggregate.

1102.2 REQUIREMENTS

a. Quality of Individual Aggregates.

(1) Provide Aggregates for Concrete that comply with **TABLE 1102-1**. Fine Aggregates for Concrete have additional Quality Requirements stated in **subsection 1102.2e.(2)**.

TABLE 1102-1: QUALITY REQUIREMENTS FOR CONCRETE AGGREGATES				
Concrete Classification	Soundness (min.)	Wear (max.)	Absorption (max.)	Acid Insoluble⁵ (min.)
Grade xx (AE)(SW) ¹	0.90	40	-	-
Grade xx (AE)(SA) ²	0.90	40	2.0	-
Grade xx (AE)(AI) ³	0.90	40	-	85
Grade xx (AE)(PB) ⁴	0.90	40	3.0	-
Bridge Overlays	0.95	40	-	85
All Other Concrete	0.90	50	-	-

¹Grade xx (AE)(SW) - Structural concrete with select coarse aggregate for wear.

²Grade xx (AE)(SA) - Structural concrete with select coarse aggregate for wear and absorption.

³Grade xx (AE)(AI) - Structural concrete with select coarse aggregate for wear and acid insolubility.

⁴Grade xx (AE)(PB) - Structural concrete with select aggregate for use in prestressed concrete beams.

⁵Acid Insoluble requirement does not apply to calcite cemented sandstone.

- Soundness (KTMR-21) requirements do not apply to aggregates having less than 10% material retained on the No. 4 sieve.
- Wear (AASHTO T 96) requirements do not apply to aggregates having less than 10% retained on the No. 8 sieve.
- Absorption KT-6 Procedure I for material retained on the No. 4 sieve. Apply the maximum absorption to the portion retained on the No. 4 sieve.

(2) All predominately siliceous aggregate must comply with the Wetting & Drying Test requirements, or be used with a Coarse Aggregate Sweetener, or will require Supplemental Cementitious Materials (SCM) to prevent Alkali Silica Reactions (ASR). When an SCM is utilized, provide the results of mortar expansion tests of ASTM C 1567 using the project's mix design concrete materials at their designated percentages. Provide a mix with a maximum expansion of 0.10% at 16 days after casting. Provide the results to the Engineer at least 15 days before placement of concrete on the project.

Wetting & Drying Test of Siliceous Aggregate for Concrete (KTMR-23)

Concrete Modulus of Rupture:

- At 60 days, minimum550 psi

- At 365 days, minimum 550 psi

Expansion:

- At 180 days, maximum..... 0.050%
- At 365 days, maximum..... 0.070%

Aggregates produced from the following general areas are exempt from the Wetting and Drying Test:

- Blue River Drainage Area.
- The Arkansas River from Sterling, west to the Colorado state line.
- The Neosho River from Emporia to the Oklahoma state line.

(3) Coarse Aggregate Sweetener. Types and proportions of aggregate sweeteners to be used with Mixed Aggregates are listed in **TABLE 1102-2**.

TABLE 1102-2: COARSE AGGREGATE SWEETENER	
Type of Coarse Aggregate Sweetener	Proportion Required by Percent Weight
Crushed Sandstone*	40 (minimum)
Crushed Limestone or Dolomite*	40 (minimum)
Siliceous Aggregates meeting subsection 1102.2a.(2)	40 (minimum)
Siliceous Aggregates not meeting subsection 1102.2a.(2) **	30 (maximum)

*Waive the minimum portion of Coarse Aggregate Sweetener for all intermediate and fine aggregates that comply with the wetting and drying requirements for Siliceous Aggregates. In this case, combine the intermediate, fine and coarse aggregate sweetener in proportions required to comply with the requirements of **subsection 1102.2a.(3)**

**To be used only with intermediate and fine aggregates that comply with the wetting and drying requirements of Siliceous Aggregates unless a Supplemental Cementitious Material is utilized.

(4) Deleterious Material. Maximum allowed deleterious substances by weight are:

- Clay lumps and friable particles (KT-7) 1.0%
- Coal (AASHTO T 113)..... 0.5%
- Shale or Shale-like material (KT-8)..... 0.5%
- Sticks (wet) (KT-35)..... 0.1%
- Total allowable deleterious 1.5%

b. Mixed Aggregates.

(1) Composition. Provide coarse, intermediate, and fine aggregates in a combination necessary to meet **subsection 1102.2b.(2)**. Use a proven optimization method such as ACI 302.1 or other method approved by the Engineer. Aggregates may be from a single source or combination of sources.

(2) Product Control.

(a) Gradations such as those shown in **TABLE 1102-3** have proven satisfactory in reducing water demand while providing good workability. Adjust mixture proportions whenever individual aggregate grading varies during the course of the work. Use the gradations shown in **TABLE 1102-3**, or other gradation approved by the Engineer.

Optimization is not required for concrete for patching pavements more than 10 years old, or Commercial Grade Concrete. The Engineer may waive the optimization requirements if the concrete meets all the requirements of **DIVISION 400**.

Follow these guidelines:

1. Do not permit the percent retained on two adjacent sieve sizes to fall below 4%;
2. Do not allow the percent retained on three adjacent sieve sizes to fall below 8%; and
3. When the percent retained on each of two adjacent sieve sizes is less than 8%, the total percent retained on either of these sieves and the adjacent outside sieve should be at least 13%.

(for example, if both the No. 4 and No. 8 sieves have 6% retained on each, then:

- 1) the total retained on the 3/8 in. and No. 4 sieves should be at least 13%, and
- 2) the total retained on the No. 8 and No. 16 sieves should be at least 13%.)

TABLE 1102-3: ALLOWABLE GRADING FOR MIXED AGGREGATES FOR CONCRETE													
Type	Usage	Percent Retained - Square Mesh Sieves											
		1 1/2"	1"	3/4"	1/2"	3/8"	No. 4	No. 8	No. 16	No. 30	No. 50	No. 100	No. 200
MA-3	Optimized All Concrete		0	2-12	Note ¹	Note ¹	Note ¹	Note ¹	Note ²	Note ²	Note ²	95-100 ³	98-100 ⁴
MA-4	Optimized All Concrete	0	2-12	Note ¹	Note ¹	Note ¹	Note ¹	Note ¹	Note ²	Note ²	Note ²	95-100 ³	98-100 ⁴
MA-5	Optimized Drilled Shafts		0	2-12	8 min	22-34		55-65		75 min		95-100	98-100
MA-6	Optimized for Bridge Overlays		0	0	2-12	Note ¹	Note ¹	Note ¹	Note ²	Note ²	Note ²	95-100 ³	98-100 ⁴
MA-7	Contractor Design KDOT Approved	Proposed Grading that does not correspond to other limits in this table but meet the requirements for concrete in DIVISION 400 .											98-100

¹Retain a maximum of 22% (24% for MA-6) and a minimum of 6% of the material on each individual sieve.

²Retain a maximum of 15% and a minimum of 6% of the material on each individual sieve.

³Retain a maximum of 7% on the No. 100 sieve.

⁴Retain a maximum of 2% on the No. 200 sieve.

- (b) Optimization Requirements for all Gradations, except MA-7.
 - Actual Workability must be within ± 5 of Target Workability.

Where: W_A = Actual Workability
 W_T = Target Workability
 CF = Coarseness Factor

1. Determine the Grading according to KT-2
2. Calculate the Coarseness Factor (CF) to the nearest whole number.

$$CF = \frac{+3/8'' \text{ Material \% Retained}}{+ \# 8 \text{ Material \% Retained}} \times 100$$

3. Calculate the Actual Workability (W_A) to the nearest whole number as the percent material passing the #8 sieve.

$$W_A = 100 - \% \text{ retained on \#8 sieve}$$

4. Calculate the Target Workability (W_T) to the nearest whole number where
 For 517 lbs cement per cubic yard of concrete

$$W_T = 46.14 - (CF/6)$$

For each additional 1 lb of cement per cubic yard, subtract 2.5/94 from the Target Workability.

- (c) Deleterious Substances. **Subsection 1102.2a.(4)**, as applicable.
- (d) Uniformity of Supply. Designate or determine the fineness modulus (grading factor) for each aggregate according to the procedure listed Part V, Section 5.10.5-Fineness Modulus of Aggregates (Gradation Factor) before delivery, or from the first 10 samples tested and accepted. Provide aggregate that is within ±0.20 of the average fineness modulus.

Provide a single point grading for the combined aggregates along with a plus/minus tolerance for each sieve. Use plus/minus tolerances to perform quality control checks and by the Engineer to perform aggregate grading verification testing. The tests may be performed on the combined materials or on individual aggregates, and then theoretically combined to determine compliance.

Maintain an Actual Workability within ± 5 of the Target Workability for the combined aggregate.

(3) Handling of All Aggregates.

- (a) Segregation. Before acceptance testing, remix all aggregate segregated by transit or stockpiling.
- (b) Stockpiling.
 - Maintain separation between aggregates from different sources, with different gradings or with a significantly different specific gravity.
 - Transport aggregate in a manner that promotes uniform grading.
 - Do not use aggregates that have become mixed with earth or foreign material.
 - Stockpile or bin all washed aggregate produced or handled by hydraulic methods for 12 hours (minimum) before batching. Rail shipment exceeding 12 hours is acceptable for binning provided the car bodies permit free drainage.
 - Provide additional stockpiling or binning in cases of high or non-uniform moisture.
 - Stockpile accepted aggregates in layers 3 to 5 feet thick. Berm each layer so that aggregates do not "cone" down into lower layers.

c. Coarse Aggregates for Concrete.

(1) Composition. Provide coarse aggregate that is crushed or uncrushed gravel or crushed stone meeting the quality requirements of **subsection 1102.2a**. Consider limestone, calcite cemented sandstone, rhyolite, quartzite, basalt and granite as crushed stone.

Mixtures utilizing siliceous aggregate not meeting **subsection 1102.2a.(2)** may require supplemental cementitious materials to prevent Alkali Silica Reactions. Provide the results of mortar expansion tests of ASTM C 1567 using the project's mix design concrete materials at their designated percentages. Provide a mix with a maximum expansion of 0.10% at 16 days after casting. Provide the results to the Engineer at least 15 days before placement of concrete on the project.

(2) Product Control. Use gradations such as those in **TABLE 1102-4** which have been shown to work in Optimized Mixed Aggregates, or some other gradation approved by the Engineer that will provide a combined aggregate gradation meeting **subsection 1102.2b**.

(3) Deleterious Substances. **Subsection 1102.2a.(4)**, as applicable.

TABLE 1102-4: ALLOWABLE GRADING FOR COARSE AGGREGATES									
Type	Composition	Percent Retained - Square Mesh Sieves							
		1½"	1"	¾"	½"	⅜"	No. 4	No. 8	No. 200
SCA-1	Siliceous Gravel or Crushed Stone	0	0-10	14-35	-	50-75	-	95-100	98-100
SCA-2	Siliceous Gravel or Crushed Stone			0	0-35	30-70	75-100	95-100	98-100
SCA-4	Siliceous Gravel or Crushed Stone		0	0-20				95-100	98-100

d. Intermediate Aggregate for Concrete.

(1) Composition. Provide intermediate aggregate for mixed aggregates (IMA) that is crushed stone, natural occurring sand, or manufactured sand meeting the quality requirements of **subsection 1102.2a**.

(2) Product Control. Provide IMA grading when necessary to provide a combined aggregate gradation meeting **subsection 1102.2b**.

(3) Deleterious Substances. **Subsection 1102.2a.(4)**, as applicable.

(4) Organic Impurities (AASHTO T 21). The color of the supernatant liquid is equal to or lighter than the reference standard solution.

e. Fine Aggregates for Concrete.

(1) Composition.

- (a) Type FA-A. Provide either singly or in combination natural occurring sand resulting from the disintegration of siliceous or calcareous rock, or manufactured sand produced by crushing predominately siliceous materials meeting the quality requirements of **subsection 1102.2a**, and **1102.2e.(2)**.

(b) Type FA-C. Provide crushed siliceous aggregate, steel slag, or chat that is free of dirt, clay, and foreign or organic material.

(2) Additional Quality Requirements for FA-A.

(a) Mortar strength and Organic Impurities. If the DME determines it is necessary, because of unknown characteristics of new sources or changes in existing sources, provide fine aggregates that comply with the following:

- Mortar Strength (KTMR-26). Compressive strength when combined with Type III (high early strength) cement:
 - At age 24 hours, minimum 100%*
 - At age 72 hours, minimum 100%*
- *Compared to strengths of specimens of the same proportions, consistency, cement and standard 20-30 Ottawa sand.
- Organic Impurities (AASHTO T 21). The color of the supernatant liquid is equal to or lighter than the reference standard solution.

(b) Provide FA-C for Multi/Single-Layer and Slurry Polymer Concrete Overlay complying with **TABLE 1102-5**.

TABLE 1102-5: QUALITY REQUIREMENTS FOR MULTI/SINGLE-LAYER AND SLURRY POLYMER CONCRETE OVERLAY		
Property	Requirement	Test Method
Soundness, minimum	0.92	KTMR-21
Wear, maximum	30%	AASHTO T 96
Acid Insoluble Residue, minimum	55%	KTMR-28
Uncompacted Voids Fine Aggregate, minimum	45	KT-50
Moisture Content, maximum	0.2%	KT-11

(3) Product Control.

(a) Size Requirements. Provide FA-C for Multi/Single-Layer and Slurry Polymer Concrete Overlays complying with **TABLE 1102-6**. Provide FA-A that comply with **TABLE 1102-6** or some other gradation approved by the Engineer that will provide a combined aggregate gradation meeting **subsection 1102.2.b**.

TABLE 1102-6: GRADING REQUIREMENTS FOR FINE AGGREGATES FOR CONCRETE								
Type	Percent Retained-Square Mesh Sieves							
	3/8"	No. 4	No. 8	No. 16	No. 30	No. 50	No. 100	No. 200
FA-A	0	0-10	0-27	15-55	40-77	70-93	90-100	98-100
FA-C	0	0	25-70	95-100	98-100	98-100	98-100	98-100

(b) Deleterious Substances. **Subsection 1102.2a.(4)**, as applicable.

f. Miscellaneous Aggregates for Concrete.

(1) Aggregates for Mortar Sand, Type FA-M.

(a) Composition. Provide aggregates for mortar sand, Type FA-M that is natural occurring sand.

(b) Quality.

- Mortar strength and Organic Impurities. If the DME determines it is necessary, because of unknown characteristics of new sources or changes in existing sources, provide aggregates for mortar sand, Type FA-M that comply with the following:
 - Mortar Strength (KTMR-26). Compressive strength when combined with Type III (high early strength) cement:
 - At age 24 hours, minimum 100%*
 - At age 72 hours, minimum 100%*

* Compared to strengths of specimens of the same proportions, consistency, cement and standard 20-30 Ottawa sand.

- Organic Impurities (AASHTO T 21). The color of the supernatant liquid is equal to or lighter than the reference standard solution.

(c) Product Control.

- Size Requirements. Provide aggregates for mortar sand, Type FA-M that comply with **TABLE 1102-7**.

TABLE 1102-7: GRADING REQUIREMENTS FOR MORTAR SAND								
Type	Percent Retained - Square Mesh Sieves							Gradation Factor
	No. 4	No. 8	No. 16	No. 30	No. 50	No. 100	No. 200	
FA-M	0	0-2	0-30	20-50	50-75	90-100	98-100	1.70-2.50

- Deleterious Substances. **Subsection 1102.2a.(4)**, as applicable.

(2) Lightweight Aggregate.

(a) Composition. Provide a lightweight aggregate consisting of expanded shale, clay or slate produced from a uniform deposit of raw material.

(b) Quality.

- Soundness, minimum (KTMR-21) 0.90
- Loss on Ignition 5%

(c) Product Control.

- Size Requirements. Use gradations such as those in **TABLES 1102-4** and **1102-6** which have been shown to work in Optimized Mixed Aggregates, or some other gradation approved by the Engineer that will provide a combined aggregate gradation meeting **subsection 1102.2b**.
- Deleterious Substances. Section 1102.2a.(4) as applicable.
- Organic Impurities (AASHTO T 21). The color of the supernatant liquid is equal to or lighter than the reference standard solution.
- Unit Weight (dry, loose weight) (max.) 1890 lbs/cu yd

(d) Concrete Making Properties. Drying shrinkage of concrete specimens prepared with lightweight aggregate proportioned as shown in the Contract Documents cannot exceed 0.07%.

(e) Uniformity of Supply. Designate or determine the fineness modulus (grading factor) according to procedure listed in Part V, Section 5.10.5-Fineness Modulus of Aggregates (Gradation Factor) before delivery, or from the first 10 samples tested and accepted. Provide aggregate that is within ± 0.20 of the average fineness modulus.

(f) Proportioning Materials. Submit mix designs for concrete using lightweight aggregate to Construction and Materials for approval prior to use.

1102.3 TEST METHODS

Test aggregates according to the applicable provisions of **SECTION 1115**.

1102.4 PREQUALIFICATION

Aggregates for concrete must be prequalified according to **subsection 1101.4**.

1102.5 BASIS OF ACCEPTANCE

The Engineer will accept aggregates for concrete based on the prequalification required by this specification and **subsection 1101.5**.

11-22-16 R (DAM)
May-17 Letting

**KANSAS DEPARTMENT OF TRANSPORTATION
SPECIAL PROVISION TO THE
STANDARD SPECIFICATIONS, 2015 EDITION**

Delete the entire SECTION 1103 and replace with the following:

SECTION 1103

AGGREGATES FOR HOT MIX ASPHALT (HMA)

1103.1 DESCRIPTION

This specification covers the quality, composition and gradation requirements of aggregates for hot mix asphalt (HMA) on QC/QA projects.

1103.2 REQUIREMENTS

a. Composition Individual Aggregates. Use aggregate from each source that complies with the gradation requirements listed in **TABLE 1103-1 and 1103-2.**

(1) Crushed Aggregates. Limit crushed aggregates to the following materials.

(a) Produce Crushed Stone (CS-1) and Crushed Stone Screenings (CS-2) by crushing limestone, sandstone, porphyry, (rhyolite, basalt, granite, and Iron Mountain Trap Rock are examples of porphyry) or other types of stone.

(b) Produce Crushed Gravel (CG) by crushing siliceous gravel containing not more than 15% non-siliceous material. If 95% or more of crushed gravel is retained on the #8 (2.65 mm) sieve, then the material must have a minimum Uncompacted Void Content of Coarse Aggregate (UVA) value of 45 when tested in accordance with KT-80. Testing will be the same frequency as KT-50. Do not use material with a UVA value less than 45.

(c) Provide Chat (CH-1) obtained during the mining of lead and zinc ores in the tri-state mining district.

(d) Consider materials complying with Mineral Filler Supplements MFS-1, MFS-2, MFS-4, and MFS-7 as crushed aggregate.

(e) Produce Crushed Steel Slag (CSSL) by crushing electric furnace steel slag. Some sources of steel slag are angular when produced and may be treated the same as crushed gravel and manufactured sand. Use steel slag with an Uncompacted Void Content of the Fine Aggregate "U" Value, determined by test method KT-50, of more than 42 and the Coarse Aggregate Angularity greater than the minimum specified value. The maximum allowable quantity of crushed steel slag is 50% of the total aggregate weight.

(f) Manufactured sand shall have an Uncompacted Void Content of the Fine Aggregate "U" Value, determined by test method KT-50, greater than or equal to 42. Produce manufactured sand by crushing siliceous sand and gravel (designate as crushed gravel (CG-2, CG-3, etc) in the mix design), or by washing or screening crushed stone (designate as crushed stone (CS-2, CS-3, etc) in the mix design), or by washing or screening chat (designate as chat (CH-2, CH-3, etc) in the mix design).

(2) Uncrushed Aggregates. Limit uncrushed aggregates to the following materials.

(a) Produce Sand-Gravel (SSG) by mixing natural sand and gravel formed by the disintegration of siliceous and/or calcareous materials.

(b) Provide Natural Sand consisting of particles formed by the natural disintegration of siliceous and/or calcareous materials. Use natural sand with an Uncompacted Void Content "U" value of less than 42.

(c) Provide Grizzly (Grizzly Waste) consisting of the matrix or bedding material occurring in conjunction with calcitic or dolomitic cemented sandstone "Quartzite", generally separated from the sandstone prior to crushing.

(d) Provide Wet Bottom Boiler Slag (WBBS) consisting of a hard angular by-product of the combustion of coal in wet-bottom boilers. Quality requirements do not exist for this material. Obtain written approval by the Chief of Construction and Materials for use in HMA. The use of WBBS does not modify the requirements for minimum contents of either crushed stone or natural sand.

(3) Mineral Filler Supplement. Provide a mineral filler supplement that is easily pulverized and free of cemented lumps, mudballs, and organic materials that complies with the following and the general requirements in **subsection 1103.2c**. Do not blend 2 or more materials to produce mineral filler supplement. Provide only 1 mineral filler supplement in each HMA design.

(a) Mineral Filler Supplement designation MFS-1 is Portland cement, blended hydraulic cements, or crushed stone.

(b) Mineral Filler Supplement designation MFS-2 is crushed limestone.

(c) Mineral Filler Supplement designation MFS-3 is water or wind deposited silty soil material.

(d) Mineral Filler Supplement designation MFS-4 is Hydrated lime. The minimum allowable quantity of MFS-4 or Hydrated Lime is 1% of the total aggregate weight when required as a supplement on the Contract Documents.

(e) Mineral Filler Supplement designation MFS-5 is volcanic ash containing a minimum of 70% glass shard. The maximum allowable quantity of MFS-5 is 5% of the total aggregate weight when specified as acceptable mineral filler supplement.

(f) Mineral Filler Supplement designation MFS-6 is fly ash. Fly ash is the finely divided residue resulting from the combustion of ground or powdered coal and is transported from the boiler by flue gasses. The maximum allowable quantity of MFS-6 is 3% of the total aggregate weight when specified as acceptable mineral filler supplement.

(g) Mineral Filler Supplement designation MFS-7 is processed chat sludge that has been dewatered at the source of supply, and does not exceed 15% moisture content by weight at the time of shipping.

(4) Reclaimed Asphaltic Pavement (RAP). Use RAP in HMA only when such an option is permitted by Contract Special Provision. Subject the RAP to the limitations (i.e. source, max. percent allowed in mix, etc.) shown on the Contract Documents and contained in the appropriate Contract Special Provisions. Screen the RAP through a 2 ¼ inch screen or grizzly before it enters the HMA plant.

Fractionated Reclaimed Asphaltic Pavement (FRAP) is defined as having two or more RAP stockpiles, where the RAP is divided into a minimum of two fractions consisting of coarse and fine fractions. Subject the FRAP to the same limitations shown on the Contract Documents and contained in the appropriate Contract Special Provisions for RAP. Comprise the maximum percentage of FRAP of coarse or fine FRAP or a combination of coarse and fine FRAP, unless otherwise stated in the Contract Documents. Utilize a separate cold feed bin for each stockpile of FRAP used. Add FRAP to the mix through the RAP collar. Include the processing requirements for each FRAP stockpile within the Quality Control Plan.

(5) Recycled Asphalt Shingles. Recycled Asphalt Shingles (RAS) are allowed in any mixture specified to use RAP. The Contractor may use the %RAP as shown in the Contract Special Provision **or** a maximum of 5% RAS and 15% total recycled material.

Drop the grade of the virgin binder one grade from both the top and the bottom grade specified for 0% RAP. For example, if a PG 64-22 is specified for 0% RAP, then the virgin grade of the binder for up to 5% RAS and 15% total recycled material is PG 58-28.

Comply with the Kansas Department of Health and Environment's Bureau of waste Management Policy 2011-P3 or current version and other regulations pertaining to the recycling of shingles.

Grind the shingles to a minus 3/8-inch size. Remove deleterious materials from waste, manufacturer, or new shingles. Use post-consumer RAS that contains less than 0.5% wood by weight or less than 1.0% total deleterious by weight. Determine the gradation of the aggregate by extraction of the binder or by using **TABLE 1103-A** as a standard gradation:

TABLE 1103-A: SHINGLE AGGREGATE GRADATION	
Sieve Size	Percent Retained
3/8 in.	0
No. 4	5
No. 8	15
No. 16	30
No. 30	50
No. 50	55
No. 100	65
No. 200	75

b. Quality of Individual Aggregates.

- Soundness, minimum (KTMR-21) 0.90
Soundness requirements do not apply to aggregates having less than 10% material retained on the No. 4 mesh sieve.
- Wear, maximum (AASHTO T 96)..... 40%
Wear requirements do not apply to aggregates having less than 10% retained on the No. 8 sieve.
- Absorption, maximum (KT-6) 4.0%
Test aggregates for absorption as follows:
 - Crushed Stone (CS-1) Test Method KT-6, Procedure I
 - Screenings (CS-2)..... Test Method KT-6, Procedure II
 - Sand Gravel (SSG)/Crushed Gravel (CG) Test Method KT-6, Procedures I & II
 Apply the specified maximum absorption to both the fraction retained on the No. 4 sieve and the fraction passing the No. 4. Screenings produced concurrently with CS-1 will be accepted without tests for absorption.
Crushed aggregates with less than 10% materials retained on the No. 4 sieve (excluding mineral filler supplements) must be produced from a source complying with the official quality requirements of this Section prior to crushing.
- Plasticity Index, the maximum P.I. for MFS-1, MFS-2, MFS-3, MFS-5, and MFS-7 is 6.

c. Product Control of Individual Aggregates

- (1) Size Requirements. Produce each individual aggregate that complies with **TABLE 1103-1 and 1103-2.**
- (2) Deleterious Substances. Provide combined aggregates free from alkali, acids, organic matter, or injurious quantities of other foreign substances that does not exceed the following maximum percentages by weight.
 - Shale or Shale-like (KT-8) 1.0%
 - Clay lumps and friable particles (KT-7) 1.0%
 - Sticks (wet) (KT-35) 0.1%
 - Coal (AASHTO T-113) 0.5%

TABLE 1103-1: REQUIREMENTS FOR INDIVIDUAL AGGREGATES							
Designation	Material	Percent Retained – Square Mesh Sieves					
		1"	1/2"	3/8"	No. 4	No. 8	No. 30
CS-1	Crushed Stone	0					95.5-100.0
CS-2	Crushed Stone Screenings		0	0 - 5			60-100
CG	Crushed Gravel	Blend gradation with other aggregates in the mix.					
CH-1	Chat	Blend gradation with other aggregates in the mix					
SSG	Sand & Sand Gravel	0					80-100
WBBS	Wet Bottom Boiler Slag		0	Blend gradation with other aggregates in the mix.			
CSSL	Crushed Steel Slag	Blend gradation with other aggregate in the mix.					

TABLE 1103-2: REQUIREMENTS FOR MINERAL FILLER SUPPLEMENTS								
Designation	Material	Percent Retained – Square Mesh Sieves						
		1”	1/2”	3/8”	No. 4	No. 8	No. 30	No. 200
MFS-1	Cement or Crushed Stone			0		0-5	0-8	0-40
MFS-2	Crushed Limestone			0		1-10		60-80
MFS-3	Silt			0	0-5			0-40
MFS-4	Hydrated Lime	Blend gradation with other aggregate in the mix						
MFS-5	Volcanic Ash			0		0-5	0-8	0-40
MFS-6	Fly Ash	Blend gradation with other aggregate in the mix						
MFS-7	Processed Chat Sludge			0		0-5	0-8	0-40

d. Stockpiling. Stockpile and handle aggregates in such a manner to prevent detrimental degradation and segregation, the incorporation of appreciable amounts of foreign material, and the intermingling of stockpiled materials.

e. Special Requirements for aggregates used in ultrathin bonded asphalt surface (UBAS). Produce each individual aggregate that complies with the gradation requirements in TABLE 1103-1 and 1103-2 and the requirements listed in TABLE 1103-3 and 1103-4.

TABLE 1103-3: INDIVIDUAL COARSE AGGREGATE PROPERTIES		
Property	Test Method	Limits
Coarse Aggregate Angularity (% min.)	KT-31	95/90 ^a
Los Angeles Abrasion (% max.) ^b	AASHTO T 96	35 ^c
Micro-Deval, (% max.) ^b	AASHTO T 327	18 ^d
Soundness (% min.)	KTMR-21	0.90 ^d
Absorption (% max.)	KT-6	4.0 ^d
Methylene Blue (% max.)	AASHTO T 330	10 ^e
An individual aggregate will be considered a coarse aggregate source if it contributes more than 5% of the total plus No. 4 sieve material of the combined aggregate (individual aggregate contribution No. 4 / total JMF retained No. 4 > 5%).		
a – 95% of the coarse aggregate has one fractured face & 90% has two or more fractured faces.		
b – Sample from stockpiled material with top size aggregate not larger than the maximum aggregate size for the mix designation type from TABLE 613-1.		
c - For calcitic or dolomitic cemented sandstone “quartzite”, the maximum percent is 40.		
d - May use KDOT’s Official Quality results		
e – Perform this test on all individual aggregates that contribute more than 1.0% to the JMF for the material passing the No. 200 sieve.		

TABLE 1103-4: INDIVIDUAL FINE AGGREGATE PROPERTIES		
Property	Test Method	Limits
Methylene Blue (% max.)	AASHTO T 330	10
Soundness (% min.)	KTMR-21	0.90 ^a
Los Angeles Abrasion (% max.)	AASHTO T 96	40 ^a
Absorption (% max.)	KT-6	4.0 ^a
a –May use KDOT’s Official Quality results.		
<ul style="list-style-type: none"> • The above requirements for wear do not apply for aggregates having less than 10% material retained on the No. 8 sieve. • The above requirements for soundness do not apply for aggregates having less than 10% material retained on the No. 4 sieve. 		

1103.3 TEST METHODS

Test aggregates according to the applicable provisions of **SECTIONS 1115 and 2501**.

1103.4 PREQUALIFICATION

Prequalify aggregate sources according to **subsection 1101.4**.

1103.5 BASIS OF ACCEPTANCE

Aggregates covered by this subsection are accepted based on the procedure described in **subsection 1101.5**.

06-22-16 C&M (BTH)
Oct-16 Letting

KT-6 Specific Gravity and Absorption of Aggregates (Coarse) Revised June 2018

Two attempts may be made by the applicant. The applicant may stop themselves once and not have that count as one of the two attempts. If the applicant stops voluntarily, draw a line at that point and note that the applicant stopped themselves then restart at the top of the next attempt.

Applicant: _____

CIT #: _____

Employer: _____

		1st Test		Stopped Test		Re-Test	
	Sample Preparation						
1.	<u>Sample passes the 2 in (50 mm) sieve and is retained on the No. 4 (4.75 mm) sieve. (3.2.1.)</u>	PASS	FAIL	PASS	FAIL	PASS	FAIL
2.	<u>Select a portion of the aggregate by splitting or quartering. The minimum mass of sample, will meet requirements of Table 1. To select sample size, use the largest sieve on which 5% or more of the material is specified to be retained. (3.2.1.1)</u>	PASS	FAIL	PASS	FAIL	PASS	FAIL
3.	<u>Thoroughly wash the sample. (3.2.1.2.)</u>	PASS	FAIL	PASS	FAIL	PASS	FAIL
4.	<u>Dry the sample to a constant mass. (3.2.1.3.)</u>	PASS	FAIL	PASS	FAIL	PASS	FAIL
	Procedure						
5.	<u>Immerse the sample in water & stir vigorously. Soak for a period of 24 +/- 4 hours. (3.2.2.1.)</u>	PASS	FAIL	PASS	FAIL	PASS	FAIL
6.	<u>Remove the sample from the water & bring to a saturated surface-dry (SSD) condition. (3.2.2.2.)</u>	PASS	FAIL	PASS	FAIL	PASS	FAIL

KT-6 Specific Gravity and Absorption of Aggregates (Coarse) Revised June 2018

7.	Weigh the sample immediately after obtaining the SSD condition. Record this value as “B”. All masses determined in this test shall be to the nearest 1 g or 0.1 % of the sample mass, whichever is greater. (3.2.2.3.)	PASS	FAIL	PASS	FAIL	PASS	FAIL
8.	Immediately after obtaining the SSD mass, immerse the sample in water, stir to remove any entrapped air and weigh. The water temperature shall be 77 +/- 2 ° F (25 +/- 1° C). (3.2.2.4.)	PASS	FAIL	PASS	FAIL	PASS	FAIL
9.	<u>Dry the sample to a constant mass at a temperature of 230 +/- 9° F (110 +/- 5° C). (3.2.2.5.)</u>	PASS	FAIL	PASS	FAIL	PASS	FAIL
10.	<u>Cool the sample to room temperature, until aggregate has cooled to a temperature that is comfortable to handle and determine the mass. Record this value as “A”. (3.2.2.6.)</u>	PASS	FAIL	PASS	FAIL	PASS	FAIL
Calculations							
11.	<u>Calculate the Bulk Specific Gravity, Saturated Surface-Dry, Apparent Specific Gravity and Absorption. (3.3.)</u>	PASS	FAIL	PASS	FAIL	PASS	FAIL

Overall Score

Circle One

1st Test

PASS

FAIL

Stopped Test

PASS

FAIL

Re-Test

PASS

FAIL

Witness Examiner:

(First Try)

Signature

Date

Witness Examiner:

(Stopped Try)

Signature

Date

Witness Examiner:

(Re-Test)

Signature

Date

Aggregate Laboratory Testing Technician
KT-6 Specific Gravity and Absorption of Aggregates
(Fine)
 Revised June 2023

Two attempts may be made by the applicant. The applicant may stop themselves once and not have that count as one of the two attempts. If the applicant stops voluntarily, draw a line at that point and note that the applicant stopped themselves then restart at the top of the next attempt.

Applicant: _____

CIT #: _____

Employer: _____

		1st Test		Stopped Test		Re-Test	
	Sample Preparation						
1.	<u>Select a portion of the aggregate by splitting or quartering. The portion selected should be of sufficient size to yield a sample weighing approximately 1,000 g all of which passes the No. 4 (4.75 mm) sieve and retained on the No. 100 (150 µm) sieve. (4.2.1.1.)</u>	PASS	FAIL	PASS	FAIL	PASS	FAIL
2.	<u>Screen the portion selected over the No. 4 (4.75 mm) sieve and discard all material retained on that sieve. (4.2.1.2.)</u>	PASS	FAIL	PASS	FAIL	PASS	FAIL
3.	<u>Wash the sample over the No.100 sieve to remove dust. (4.2.1.3.)</u>	PASS	FAIL	PASS	FAIL	PASS	FAIL
4.	<u>Dry the sample to a constant mass in the oven. (4.2.1.4.)</u>	PASS	FAIL	PASS	FAIL	PASS	FAIL
	Procedure						
5.	<u>Immerse the sample in water and stir vigorously. Soak for a period of 24 +/- 4 hours. (4.2.2.1.)</u>	PASS	FAIL	PASS	FAIL	PASS	FAIL
6.	<u>Place the saturated sample in a drying pan and allow to dry in air for a short time. Stir the sample regularly to ensure uniform drying. (4.2.2.2.1.)</u>	PASS	FAIL	PASS	FAIL	PASS	FAIL
7.	<u>Transfer the sample to another drying pan. (4.2.2.2.2.)</u>	PASS	FAIL	PASS	FAIL	PASS	FAIL

Aggregate Laboratory Testing Technician
KT-6 Specific Gravity and Absorption of Aggregates
(Fine)
Revised June 2023

		1st Test		Stopped Test		Re-Test	
8.	Stir the sample regularly and transfer it frequently from pan to pan until SSD condition is reached as indicated by the absence of free moisture on the bottom of the pan. (4.2.2.2.4.)	PASS	FAIL	PASS	FAIL	PASS	FAIL
9.	Determine the mass of the empty flask. Record the value as “F”.(4.2.2.2.5)	PASS	FAIL	PASS	FAIL	PASS	FAIL
10.	Immediately split out and weigh a sample of the SSD material weighing not less than 500 g. Record this value as “B” Place sample in flask. (4.2.2.3.)	PASS	FAIL	PASS	FAIL	PASS	FAIL
11.	Fill the flask to a level slightly below the calibration mark with water at a temperature of 77 +/- 2°F (25 +/- 1°C). (4.2.2.4.)	PASS	FAIL	PASS	FAIL	PASS	FAIL
12.	Rotate the flask in an inclined position to eliminate all air bubbles. Do not shake. Allow the flask to sit for several minutes then roll the flask again. Continue the process until there are no visible air bubbles present. (4.2.2.5.)	PASS	FAIL	PASS	FAIL	PASS	FAIL
13.	Place the flask in the water bath until the temperature of the material inside the flask is the same as that of the water bath. (4.2.2.6.)	PASS	FAIL	PASS	FAIL	PASS	FAIL
14.	Fill the flask to the calibrated mark, remove it from the water bath and wipe all moisture from the outside surface. (4.2.2.7.)	PASS	FAIL	PASS	FAIL	PASS	FAIL
15.	Weigh the flask and its contents to the nearest 0.1 g. Record the value as “K”. (4.2.2.8.)	PASS	FAIL	PASS	FAIL	PASS	FAIL
16.	<u>Remove the aggregate from the flask and dry to a constant mass in the oven at a temperature of 230 +/-9°F (110 +/-5°C).</u> (4.2.2.9.)	PASS	FAIL	PASS	FAIL	PASS	FAIL

Aggregate Laboratory Testing Technician KT-6 Specific Gravity and Absorption of Aggregates (Fine)

Revised June 2023

		1st Test		Stopped Test		Re-Test	
17.	<u>Cool the sample to room temperature and weigh. Record the value as "A".(4.2.2.10.)</u>	PASS	FAIL	PASS	FAIL	PASS	FAIL
Calculations							
18.	<u>Determine the mass of the flask filled to the calibration line with water at 77 °F (25 °C) and subtract the mass of the flask to determine the mass of water the flask will hold. Record this value as "C". This step need not be performed for every test but must be done a minimum of once every year. (4.2.2.11)</u>	PASS	FAIL	PASS	FAIL	PASS	FAIL
19.	<u>Calculate the Bulk Specific Gravity, Saturated Surface-Dry, Apparent Specific Gravity and Absorption. (4.3.)</u>	PASS	FAIL	PASS	FAIL	PASS	FAIL

Overall Score

Circle One

1st Test

PASS

FAIL

Stopped Test

PASS

FAIL

Re-Test

PASS

FAIL

Witness Examiner:

(First Try)

Signature

Date

Witness Examiner:

(Stopped Try)

Signature

Date

Witness Examiner:

(Re-Test)

Signature

Date

Aggregate Laboratory Testing Technician
KT-31 Determination of Percentage of Crushed Particles in Crushed
Gravel
 Revised June 2018

Two attempts may be made by the applicant. The applicant may stop themselves once and not have that count as one of the two attempts. If the applicant stops voluntarily, draw a line at that point and note that the applicant stopped themselves then restart at the top of the next attempt.

Applicant: _____

CIT #: _____

Employer: _____

		1st Test		Stopped Test		Re-Test	
	Sample Preparation						
1.	<u>Obtain the test sample by quartering or splitting according to KT-01. (4.1.)</u>	PASS	FAIL	PASS	FAIL	PASS	FAIL
2.	<u>The sample shall be of sufficient size to yield the minimum dry mass shown in Table 1 after washing over the No. 4 (4.75 mm) sieve. (4.1.)</u>	PASS	FAIL	PASS	FAIL	PASS	FAIL
3.	<u>Screen the sample over a No. 4 (4.75 mm) sieve and discard all material passing the sieve. (4.1.)</u>	PASS	FAIL	PASS	FAIL	PASS	FAIL
4.	<u>Wash the retained material over a No. 4 (4.75 mm) sieve and dry the sample to constant mass at 230 +/- 9°F (110 +/- 5°C). (4.1)</u>	PASS	FAIL	PASS	FAIL	PASS	FAIL
	Procedure						
5.	<u>Weigh the material retained on the No. 4 (4.75 mm) sieve to the nearest gram. Record this mass as the original dry mass. (5.1.)</u>	PASS	FAIL	PASS	FAIL	PASS	FAIL
6.	<u>Spread the material in a thin layer on a clean flat surface so that each particle can be examined. (5.2.)</u>	PASS	FAIL	PASS	FAIL	PASS	FAIL
7.	<u>Separate the crushed particles from uncrushed particles. Any particle appearing to have one or more fractured faces shall be considered a crushed particle. (5.3.)</u>	PASS	FAIL	PASS	FAIL	PASS	FAIL

Aggregate Laboratory Testing Technician
KT-31 Determination of Percentage of Crushed Particles in Crushed
Gravel
 Revised June 2018

		1st Test		Stopped Test		Re-Test	
8.	Separate the crushed particles into three piles; uncrushed particles, particles with two or more fractured faces and particles with one fractured face. (6.3)	PASS	FAIL	PASS	FAIL	PASS	FAIL
Calculations							
9.	<u>Compute the percentage of crushed particles.</u> (7.1.)	PASS	FAIL	PASS	FAIL	PASS	FAIL

Overall Score

Circle One

1st Test

PASS

FAIL

Stopped Test

PASS

FAIL

Re-Test

PASS

FAIL

Witness Examiner:

(First Try)

Signature

Date

Witness Examiner:

(Stopped Try)

Signature

Date

Witness Examiner:

(Re-Test)

Signature

Date

KT-55 Plastic Fines In Combined Aggregates By Use Of The Sand Equivalent Test

Revised: March 2020

Two attempts may be made by the applicant. The applicant may stop themselves once and not have that count as one of the two attempts. If the applicant stops voluntarily, draw a line at that point and note that the applicant stopped themselves then restart at the top of the next attempt.

Applicant: _____

CIT #: _____

Employer: _____

		1st Test		Stopped Test		Re-Test	
	Sample Preparation						
1.	<u>Sample pulverized and passed through No. 4 (4.75mm) sieve. (5.1.)</u>	PASS	FAIL	PASS	FAIL	PASS	FAIL
2.	<u>Clean all fines from the particles retained on the No. 4 (4.75 mm) sieve and include with the material passing the No. 4 (4.75 mm) sieve. (5.1)</u>	PASS	FAIL	PASS	FAIL	PASS	FAIL
3.	Split or quartered to yield slightly more than four-3 oz (85 mL) tin measures of material passing the No. 4 (4.75 mm) sieve. Dampen the material to avoid loss or segregation of the fines if necessary. (5.2.)	PASS	FAIL	PASS	FAIL	PASS	FAIL
4.	Use enough minus No. 4 (4.75 mm) material to fill the tin measure so it is slightly rounded above the brim. (5.3.1.)	PASS	FAIL	PASS	FAIL	PASS	FAIL
5.	Tap the bottom edge of the tin measure on a hard surface to cause consolidation of the material as it is being filled. (5.3.1.)	PASS	FAIL	PASS	FAIL	PASS	FAIL
6.	Strike off the tin measure level full with a spatula or straightedge. (5.3.1.)	PASS	FAIL	PASS	FAIL	PASS	FAIL
7.	<u>Dry the test sample to constant mass at 230 +/- 9°F (110 +/- 5°C), cool to room temperature before testing. (5.3.2.)</u>	PASS	FAIL	PASS	FAIL	PASS	FAIL
	Procedure						

**KT-55 Plastic Fines In Combined Aggregates By Use Of The Sand
Equivalent Test
Revised: March 2020**

		1st Test		Stopped Test		Re-Test	
8.	For each test sample siphon 4 +/- 0.1 in (101.6 +/- 2.5mm) of working calcium chloride solution into the plastic cylinder. (6.1.)	PASS	FAIL	PASS	FAIL	PASS	FAIL
9.	Pour sample from the measuring tin into the plastic cylinder using the funnel to avoid spillage. (6.1.)	PASS	FAIL	PASS	FAIL	PASS	FAIL
10.	Tap the bottom of the cylinder sharply on the heel of the hand several times to release air bubbles and to promote thorough wetting of the sample. (6.1.)	PASS	FAIL	PASS	FAIL	PASS	FAIL
11.	Allow the wetted sample to stand undisturbed for 10 +/- 1 minutes. (6.2.)	PASS	FAIL	PASS	FAIL	PASS	FAIL
12.	Stopper the cylinder and loosen the material from the bottom by partially inverting the cylinder and shaking simultaneously. (6.2.)	PASS	FAIL	PASS	FAIL	PASS	FAIL
13.	Place stoppered cylinder in the mechanical shaker and set timer for 45 seconds. (6.3.)	PASS	FAIL	PASS	FAIL	PASS	FAIL
14.	Following shaking, set cylinder upright on worktable and remove stopper. (6.4.)	PASS	FAIL	PASS	FAIL	PASS	FAIL
15.	Insert irrigator tube in the cylinder and rinse material from the cylinder walls as the irrigator is lowered. Force the irrigator through the material to the bottom of the cylinder by gentle stabbing and twisting action while solution flows from tip. (6.5)	PASS	FAIL	PASS	FAIL	PASS	FAIL
16.	Apply stabbing and twisting motion until the cylinder is filled to the 15 in. (381mm) mark. (6.5.)	PASS	FAIL	PASS	FAIL	PASS	FAIL
17.	Raise the irrigator slowly without shutting off the flow so that the liquid level is maintained at 15 in (381 mm) while the irrigator is being withdrawn. Adjust the final level to 15 in. (381 mm) (6.5.)	PASS	FAIL	PASS	FAIL	PASS	FAIL

KT-55 Plastic Fines In Combined Aggregates By Use Of The Sand Equivalent Test

Revised: March 2020

		1st Test		Stopped Test		Re-Test	
18.	Start timing immediately after withdrawing the tube. Allow the cylinder and contents to stand undisturbed for 20 minutes +/- 15 seconds. (6.6.)	PASS	FAIL	PASS	FAIL	PASS	FAIL
19.	After sedimentation period, read and record the top level of the clay suspension. (6.7.)	PASS	FAIL	PASS	FAIL	PASS	FAIL
20.	Place the weighted foot assembly over the cylinder and gently lower the assembly toward the sand. Do not allow the indicator to hit the mouth of the cylinder. As the weighted foot assembly comes to rest on the sand, tip it until the indicator touches the inside of the cylinder. Subtract 10 in (254 mm) from the level indicated by the extreme top edge of the indicator and record this value as the sand reading. (6.8.)	PASS	FAIL	PASS	FAIL	PASS	FAIL
21.	If clay/sand readings fall between 0.1 in (2.5 mm) graduations, record the level of the higher graduation as the reading. (6.9.)	PASS	FAIL	PASS	FAIL	PASS	FAIL

Overall Score

Circle One

1st Test

PASS

FAIL

Stopped Test

PASS

FAIL

Re-Test

PASS

FAIL

Witness Examiner:

(First Try)

Signature

Date

Witness Examiner:

(Stopped Try)

Signature

Date

Witness Examiner:

(Re-Test)

Signature

Date

Aggregate Lab Testing Technician
KT-59 Flat and Elongated Particles In Coarse Material Test
 Revised: March 2020

Two attempts may be made by the applicant. The applicant may stop themselves once and not have that count as one of the two attempts. If the applicant stops voluntarily, draw a line at that point and note that the applicant stopped themselves then restart at the top of the next attempt.

Applicant: _____

CIT #: _____

Employer: _____

		1st Test		Stopped Test		Re-Test	
	Sampling						
1.	<u>Sample the coarse aggregate in accordance with KT-1, Section 3. (6.1.)</u>	PASS	FAIL	PASS	FAIL	PASS	FAIL
2.	<u>Obtain a large enough sample to yield the required plus 4 material listed in Section 6.2. (6.2.)</u>	PASS	FAIL	PASS	FAIL	PASS	FAIL
3.	<u>Sieve the material over the No. 4 (4.75 mm) screen, discard all material passing the No. 4 (4.75 mm) screen. (6.1.1)</u>	PASS	FAIL	PASS	FAIL	PASS	FAIL
4.	<u>Oven dry the sample to a constant mass at a temperature of 230 +/- 9°F (110 +/- 5°C). (6.1.2.)</u>	PASS	FAIL	PASS	FAIL	PASS	FAIL
5.	<u>Determine the Original Dry Mass of the sample. The mass of the plus No. 4 material shall conform to minimum mass of +4 test sample, lb (kg). Nominal Maximum Aggregate size is one size larger than the first sieve to retain more than 10%.(6.2)</u>	PASS	FAIL	PASS	FAIL	PASS	FAIL
6.	<u>Sieve the sample of coarse aggregate to be tested in accordance of KT-2. Separately retain and determine the mass of each sieve size fraction (7.1.)</u>	PASS	FAIL	PASS	FAIL	PASS	FAIL

Aggregate Lab Testing Technician
KT-59 Flat and Elongated Particles In Coarse Material Test
 Revised: March 2020

		1st Test		Stopped Test		Re-Test	
7.	<u>Reduce each size fraction larger than the No. 4 (4.75 mm) sieve present in the amount of 10% or more of the original sample in accordance with KT-1 until approximately 100 particles are obtained. (7.1.)</u>	PASS	FAIL	PASS	FAIL	PASS	FAIL
8.	With the proportional device set at a 5:1 ratio (or as required by the contract documents), test each particle in each size fraction for flat and elongated. (7.2.)	PASS	FAIL	PASS	FAIL	PASS	FAIL
9.	Set the larger opening of the proportional caliper device equal to the particle length. The particle is flat and elongated if the flattest portion of the particle can be placed through the smaller opening. Determine the proportion of the sample in each group by mass. (7.2.1.)	PASS	FAIL	PASS	FAIL	PASS	FAIL

Overall Score

Circle One

1st Test

PASS

FAIL

Stopped Test

PASS

FAIL

Re-Test

PASS

FAIL

Witness Examiner:

(First Try)

Signature

Date

Witness Examiner:

(Stopped Try)

Signature

Date

Witness Examiner:

(Re-Test)

Signature

Date